



**TOWN OF TRUMBULL, CONNECTICUT
TRUMBULL HIGH SCHOOL
ADDITIONS AND RENOVATIONS**

EMERGENCY GENERATOR

**REQUEST FOR PROPOSAL, CONDITIONS, SPECIFICATIONS,
SPECIAL PROVISIONS AND DRAWINGS**

RFQ #6029 DUE: JANUARY 23, 2014 at 3:00PM

**PREPARED FOR THE TOWN OF TRUMBULL BY:
ANTINOZZI ASSOCIATES
271 Fairfield Avenue
Bridgeport, Connecticut 06604
(203) 377-1300 - (203) 378-300 -Fax**

TABLE OF CONTENTS

GENERAL INSTRUCTIONS

Page 3 - 5	General Instructions
Page 6	References
Page 7-8	Bid Proposal Form

Division 01

General Requirements

<u>Section No.</u>	<u>Title</u>
011100	Summary of Work
012300	Alternates

Division 26

Electrical

<u>Section No.</u>	<u>Title</u>
260200	Pre-Purchase General Conditions
263213 (650KW-DEG)	650KW Diesel Emergency Generator (Base Bid)
263213 (1250KW -DEG)	1250KW Diesel Emergency Generator (Add Alternate Bid)
26300	Automatic Transfer Switches

Attachments

Drawings

<u>Section No.</u>	<u>Title</u>
Drawing E-1	Electrical One Line Diagram (Base Bid)
Drawing E-2	Electrical One Line Diagram (Add Alternate Bid)

END OF TABLE OF CONTENTS

**TOWN OF TRUMBULL, CONNECTICUT
REQUEST FOR QUOTATION (RFQ)
ADDITIONS AND RENOVATIONS
TRUMBULL HIGH SCHOOL
EMERGENCY GENERATOR**

**RFQ NUMBER: 6029 DUE: JANUARY 23, 2014 AT 3:00PM
GENERAL INSTRUCTIONS TO BIDDERS**

The Town of Trumbull, Connecticut (hereinafter referred to as Town), through the Office of the Purchasing Agent, will accept sealed bids from qualified firm or bidder for the purchase of an Emergency Generator for the Trumbull High School, in accordance with the attached specifications and requirements.

NOTE: THIS REQUEST IS FOR GENERATOR EQUIPMENT ONLY AND DOES NOT INCLUDE INSTALLATION. A SEPARATE REQUEST FOR PROPOSAL AND CONTRACT FOR OFF-LOADING INSTALLATION SHALL BE ISSUED AT A LATER DATE.

1. PREPARATION OF BIDS

Bids shall be submitted by using the enclosed BID PROPOSAL FORM that accompanies this request. Submit one (1) ORIGINAL and one (1) EXACT COPY. Bidders should submit bids in a clear, concise and legible manner to permit proper evaluation of responsive bids.

Bidders must submit a list of all equipment to be used and specification sheets for the generator equipment to allow proper bid evaluation. Bidders may also submit, under separate cover with their proposal, any samples of reports and documents that are necessary to meet the requirements (deliverables) of this request should a purchase order be awarded

2. BID SUBMISSION

Bids are to be submitted in DUPLICATE in a sealed envelope and addressed as follows:

Purchasing Agent – BID NUMBER: 6029, DUE: JANUARY 23, 2014
Town of Trumbull
5866 Main Street
Trumbull, CT 06611

Please be advised that the person signing the formal proposal must be authorized by your organization to contractually bind your firm with regard to prices and related contractual obligations for the delivery period requested.

3. BID TIME

- a) Bids shall be received at the office of the Purchasing Agent, Town Hall, prior to the advertised hour of opening, at which time all proposals will be publicly opened and read aloud. Any bid received after the due date and time noted above shall not be accepted or opened.
- b) A bidder may withdraw a proposal at any time prior to the above scheduled date and time. Any bid received after the above scheduled date and time shall not be considered or opened.

4. TOWN OPTIONS

- a) The Town of Trumbull reserves the right to reject any and all bids and does not bind itself to accept the lowest bid or any proposal. The Town reserves the right to ask for new bids in whole or in part, or to reject any or all bids, or any part thereof, and to waive any requirements, irregularities, technical defects or service therein when it is deemed to be in the best interest of the Town.
- b) If a bid proposal does not meet or better the required specifications, requirements, and scope of work requested on all points that must be outlined in a letter attached to the bid proposal otherwise it will be presumed that the bid as proposed is in accordance with the required specifications.

5. TAXES

All purchases made by the Town, and associated with the award of this requirement shall be tax exempt. Any taxes must not be included in bid prices. A Town Tax Exemption Certificate shall be furnished upon request.

6. **INQUIRIES**

All inquiries regarding this request shall be answered up to the close of business January 17, 2014 after which time no additional questions will be accepted. To ensure consistent interpretation of certain items, answers to questions the Town deems to be in the interest of all bidders will be made available in writing or by Fax as appropriate to all bidders. Inquiries or requests for onsite visits may be directed to the **Mr. Paul Lisi, Antinozzi Associates, (203.377.1300)**.

Additionally, after proposals are received, the Town reserves the right to communicate with any or all of the bidders to clarify the provisions of Proposals. The Town further reserves the right to request additional information from any bidder at any time after proposals are opened.

7. **AWARD AND AUTHORITY**

The Town Purchasing Agent will issue notification of award in writing.

8. **PRICING**

- a) All prices quoted are to be firm for a period of at least one hundred and sixty (160) days following bid opening.
- b) Special Consideration will be given to responses with extended firm price dates. The Town is always interested in any and all cost reduction opportunities.

9. **ASSIGNMENT OF RIGHTS, TITLES, AND INTERESTS**

Any assignment or subcontracting by a bidder for goods to be provided, in whole or in part, and any other interest in conjunction with Town procurement shall not be permitted without the express written consent of the Town of Trumbull.

10. **HOLD HARMLESS CLAUSE**

Bidder agrees to indemnify, hold harmless and defend the Town from and against any and all liability for loss, damage or expense which the Town may suffer or for which the Town may be held liable by reason of injury, including death, to any person or damage to any property arising out of or in any manner connected with the operations to be performed under an agreement with the Town, whether or not due in whole or in part of any act, omission or negligence of the Town or any of his representatives or employees.

11. **WORK REGULATIONS, PREVAILING WAGE, AND STANDARDS**

All work activities performed in association with this request must be performed and completed for the Town in accordance with current Federal State and Local regulations. State of Connecticut Prevailing Wage standards apply for this project. All services performed shall also conform to the latest OSHA standards and/or regulations.

12. **BID BOND**

A Bid Bond payable to the Owner must accompany each Bid for ten (10%) percent of the total amount of the Bid. As soon as the Bid prices have been compared, the Owner will return the bonds of all except the three lowest responsible Bidders. When the Agreement is executed, the bonds of the two remaining unsuccessful Bidders will be returned. The Bid Bond of the successful Bidder will be retained until the Payment Bond and Performance Bond have been executed and approved, after which it will be returned. A certified check may be used in lieu of a Bid Bond.

13. **CONFLICT OF INTEREST**

No purchase shall be made from nor shall services (other than services as an officer, agent, or employee of the Town) be secured from any officer or employee of the Town, or from any partnership or corporation in which such officer or employee is a partner or officer, or holds a substantial interest, unless such relationship and the fact that such purchase is contemplated shall be made known in writing to the agency making such purchase, and notice thereof posted, for at least five (5) days before such purchase be made, in the office of the agency making such purchase and in a public place in the Trumbull Town Hall.

14. REFERENCES

Bidders must provide five (5) commercial references using the attached form.

15. SPECIFICATIONS

- a) Should any Bidder find discrepancies in the Specifications, or be in doubt as to the exact meaning, notify the Town at once. The Town may then, at their option, issue Addenda clarifying same. The Town shall not be responsible for oral instructions or misinterpretations of Specifications.
- b) The Town reserves the right to issue Addenda at any time prior to the Bid Opening. All such Addenda become, upon issuance part of the Specification. Each Bidder shall cover such Addenda in the proposal and shall acknowledge receipt of same on the blank provided therefore.
- c) The Town reserves the right to require any or all Bidders to submit statements as to previous experience in the delivery of similar equipment; and as to financial and technical organizations and resources available for this work. The mere opening and reading aloud of a bid shall not constitute or imply the Town's acceptance of the suitability of a Bidder or the bid, nor shall possession of Drawings or Specifications constitute an invitation to bid. The competency and responsibility of Bidders as well as the number of working days required for delivery shall be considered in making an award.

16. ADENDUMS

It is the responsibility of the bidder to verify prior to final submittal of a bid or bid if any addenda to this request have been issued. Any addenda to this request shall be posted on the Town of Trumbull website www.trumbull-ct.gov under the Purchasing Department's section. Bidders also call the Purchasing Department directly 203.452.5042 for inquiries regarding addenda.

17. LIQUIDATED DAMAGES – TIME IS OF THE ESSENCE

Non-compliance with the scheduled delivery date of the Contract shall result in engineering charges as follows:

- The selected firm shall pay liquidated damages of \$1000.00 per working day for each day after the agreed Contract completion date up to, and including, the actual date of delivery.

**TOWN OF TRUMBULL, CONNECTICUT
REQUEST FOR QUOTATION (RFQ)
ADDITIONS AND RENOVATIONS
TRUMBULL HIGH SCHOOL
EMERGENCY GENERATOR**

RFQ NUMBER: 6029 DUE: JANUARY 23, 2014 AT 3:00PM

REFERENCES

(To be submitted with proposal – attach additional pages as necessary)

List references for similar services provided for at least five (5) clients in the past five (5) years (attach any other client references if desired). **PLEASE NOTE IT IS THE TOWN'S INTENT TO COMMUNICATE WITH THE REFERENCES LISTED HEREIN.**

CLIENT 1:

Organization Name: _____
Contact Name: _____ Phone: _____
Service Dates: _____
Project(s): _____

CLIENT 2:

Organization Name: _____
Contact Name: _____ Phone: _____
Service Dates: _____
Project(s): _____

CLIENT 3:

Organization Name: _____
Contact Name: _____ Phone: _____
Service Dates: _____
Project(s): _____

CLIENT 4:

Organization Name: _____
Contact Name: _____ Phone: _____
Service Dates: _____
Project(s): _____

CLIENT 5:

Organization Name: _____
Contact Name: _____ Phone: _____
Service Dates: _____
Project(s): _____

**TOWN OF TRUMBULL, CONNECTICUT
REQUEST FOR QUOTATION (RFQ)
EMERGENCY GENERATOR
BID PROPOSAL FORM**
RFQ NUMBER: 6029 DUE: JANUARY 23, 2014 AT 3:00PM

(TO BE ON BIDDER'S LETTERHEAD)

To: Purchasing Agent
 Town of Trumbull
 5688 Main Street
 Trumbull, CT 06611

Project: TRUMBULL HIGH SCHOOL
 EMERGENCY GENERATOR
 TRUMBULL, CONNECTICUT

Date: _____

Submitted by:
(Full name)

(Full address)

1. OFFER

Pursuant to and in compliance with the Invitation to Bid relating thereto, the Undersigned,

_____ himself/herself with the conditions present and carefully examined all the documents (including the drawings and specifications dated December 9, 2013), General Instructions, Bid Proposal Form, etc., together with all Addenda issued and received prior to closing time for receipt of Bids as prepared by Antinozzi Associates hereby offers and agrees as follows:

To provide all materials, all labor and all else whatsoever necessary to erect and properly finish all work in accordance with said documents for the above mentioned projects to the satisfaction of the Architect and Owner for the stipulated sum of

Base Bid (in words) _____

Base Bid (in figures) \$ _____

Enclosed herewith is the Bid Guaranty (10% of Base Bid minimum), in the form of: () Bid Bond () Certified Check

All State of Connecticut taxes are excluded from the Bid Sum.

2. ACCEPTANCE

This offer shall be open to acceptance for ninety (90) days from the Bid opening date.

If this Bid is accepted by the Owner within the time period stated above, Undersigned will:

Execute this Agreement within ten days of receipt of acceptance of this Bid.

Furnish the required bond (s) within ten days of receipt of acceptance of this Bid.

Commence work within seven days after written Notice to Proceed or Contract signing.

If this Bid is accepted within the time stated, and the Undersigned fails to provide the required Bond(s), the Owner may charge against the Undersigned the difference between the amount of this bid and the amount for which the contract for the work is subsequently executed, irrespective of whether the amount thus due exceeds the amount of the bid guaranty.

In the event this Bid is not accepted within the time stated above, the required security deposit shall be returned to the undersigned, in accordance with the provisions of the Instructions to Bidders; unless a mutually satisfactory arrangement is made for its retention and validity for an extended period of time.

3. CONTRACT TIME

If this Bid is accepted, the Undersigned will deliver all equipment to the site no later than **May 30, 2014**. It is additionally understood that liquidated damages, in the amount of \$1,000.00 per day, will be assessed for failure to deliver all equipment within the above time period as described in the General Conditions.

4. CHANGES TO THE WORK

Equitable adjustments for Changes in the Work will be net cost plus a percentage fee in accordance with the General Conditions.

5. ADDENDA

The following Addenda have been received. The modifications to the Bid Documents noted therein have been considered and all costs thereto are included in the Base Bid.

Addenda # _____

6. ALTERNATES

- A. Add Alternate No.1 – Provide a 1,250 KW generator and associated automatic transfer switches in lieu of the specified base bid 650 KW generator and associated automatic transfer switches.

ADD THE SUM OF \$ _____

7. BID FORM SIGNATURE (S)

The Corporate Seal

(Print the full name of your Proprietorship, Partnership, or Corporation)

Was hereunto affixed in the presence of:

(Authorized signing officer) (Title)

(Seal)

(Authorized signing officer) (Title)

If the Bid is a joint venture or partnership, add additional forms of execution for each member of the joint venture in the appropriate form or forms as above.

END OF BID FORM

SECTION 011100 - SUMMARY

PART 1 - GENERAL

1.1 RELATED DOCUMENTS

- A. Drawings and general provisions of the Contract, including General and Supplementary Conditions and other Division 1 Specification Sections, apply to this Section.

1.2 SUMMARY

- A. This Section includes the following:
 - 1. Work covered by the Contract Documents.
 - 2. Type of the Contract.
 - 3. Work under other contracts.
 - 4. Specification formats and conventions.

1.3 WORK COVERED BY CONTRACT DOCUMENTS

- A. Project Identification: Trumbull High School – New Emergency Generator
 - 1. Project Location: 72 Strobel Road, Trumbull, Connecticut
- B. Owner: Town of Trumbull, 5688 Main Street, Trumbull, Connecticut
- C. Architect: Antinozzi Associates, PC.
- D. The Work consists of the following:
 - 1. The base bid work includes supplying and delivering to the project location, a new 650 KW diesel generator and automatic transfer switches as specified. Scope includes, but is not limited to supplying and delivering generator and transfer switches, preparing product submittals, start-up and testing. Off loading and installation shall be by others.
 - 2. The alternate bid work includes supplying and delivering to the project location, a new 1,250 KW diesel generator and automatic transfer switches as specified in lieu of the base bid 650 KW generator and automatic transfer switches. Scope includes, but is not limited to supplying and delivering generator and transfer switches, preparing product submittals, start-up and testing. Off loading and installation shall be by others.

1.4 TYPE OF CONTRACT

- A. Project will be constructed under a single prime contract.

1.5 WORK UNDER OTHER CONTRACTS

- A. General: Cooperate fully with separate contractors so work on those contracts may be carried out smoothly, without interfering with or delaying work under this Contract. Coordinate the Work of this Contract with work performed under separate contracts.
- B. Future Work: Owner will award a separate contract for the following additional work to be performed at site after delivery of equipment. Completion of this work will depend on successful completion of preparatory work under this Contract and shall be incorporated and coordinated into the Contractor's schedule.
 - 1. Off loading and installation: A separate contract will be awarded for the off-loading and installation of the generator, automatic transfer switches and associated work.

1.6 SPECIFICATION FORMATS AND CONVENTIONS

- A. Specification Format: The Specifications are organized into Divisions and Sections using the 16-division format and CSI/CSC's "MasterFormat" numbering system.
 - 1. Section Identification: The Specifications use Section numbers and titles to help cross-referencing in the Contract Documents. Sections in the Project Manual are in numeric sequence; however, the sequence is incomplete because all available Section numbers are not used. Consult the table of contents at the beginning of the Project Manual to determine numbers and names of Sections in the Contract Documents.
 - 2. Division 1: Sections in Division 1 govern the execution of the Work of all Sections in the Specifications. General Conditions and Supplemental Conditions may override Division 1 Specification Sections.
- B. Specification Content: The Specifications use certain conventions for the style of language and the intended meaning of certain terms, words, and phrases when used in particular situations. These conventions are as follows:
 - 1. Abbreviated Language: Language used in the Specifications and other Contract Documents is abbreviated. Words and meanings shall be interpreted as appropriate. Words implied, but not stated, shall be inferred as the sense requires. Singular words shall be interpreted as plural, and plural words shall be interpreted as singular where applicable as the context of the Contract Documents indicates.
 - 2. Imperative mood and streamlined language are generally used in the Specifications. Requirements expressed in the imperative mood are to be performed by Contractor. Occasionally, the indicative or subjunctive mood may be used in the Section Text for clarity to describe responsibilities that must be fulfilled indirectly by Contractor or by others when so noted.
 - a. The words "shall," "shall be," or "shall comply with," depending on the context, are implied where a colon (:) is used within a sentence or phrase.

13030

Town of Trumbull

Trumbull High School
Emergency Generator

PART 2 - PRODUCTS (Not Used)

PART 3 - EXECUTION (Not Used)

END OF SECTION 011100

SECTION 012300 - ALTERNATES

PART 1 - GENERAL

1.1 RELATED DOCUMENTS

- A. Drawings and general provisions of the Contract, including General and Supplementary Conditions and other Division 1 Specification Sections, apply to this Section.

1.2 SUMMARY

- A. This Section includes administrative and procedural requirements for alternates.

1.3 DEFINITIONS

- A. Alternate: An amount proposed by bidders and stated on the Bid Form for certain work defined in the Bidding Requirements that may be added to or deducted from the Base Bid amount if Owner decides to accept a corresponding change either in the amount of construction to be completed or in the products, materials, equipment, systems, or installation methods described in the Contract Documents.
 - 1. The cost or credit for each alternate is the net addition to or deduction from the Contract Sum to incorporate alternate into the Work. No other adjustments are made to the Contract Sum.

1.4 PROCEDURES

- A. Coordination: Modify or adjust affected adjacent work as necessary to completely integrate work of the alternate into Project.
 - 1. Include as part of each alternate, miscellaneous devices, accessory objects, and similar items incidental to or required for a complete installation whether or not indicated as part of alternate.
- B. Notification: Immediately following award of the Contract, notify each party involved, in writing, of the status of each alternate. Indicate if alternates have been accepted, rejected, or deferred for later consideration. Include a complete description of negotiated modifications to alternates.
- C. Execute accepted alternates under the same conditions as other work of the Contract.
- D. Schedule: A Schedule of Alternates is included at the end of this Section. Specification Sections referenced in schedule contain requirements for materials necessary to achieve the work described under each alternate.

13030

Town of Trumbull

Trumbull High School
Emergency Generator

PART 2 - PRODUCTS (Not Used)

PART 3 - EXECUTION

3.1 SCHEDULE OF ALTERNATES

- A. Add Alternate No.1 – Provide a 1,250 KW generator and associated automatic transfer switches in lieu of the specified base bid 650 KW generator and associated automatic transfer switches.

ADD THE SUM OF \$ _____

END OF SECTION 012300

SECTION 260200 – PREPURCHASE GENERAL CONDITIONS**PART 1 - GENERAL****1.1 GENERAL CONDITIONS AND BID PROPOSAL SUBMITTAL REQUIREMENTS**

- A. The manufacturer shall submit as part of Bid Proposal an item-by-item adherence to all requirements of these specifications, one-line diagrams, and any other data requested. Identify all proposed equipment with weights, dimensions, and access requirements. Lack of these requirements in the manufacturer's technical proposal shall be considered as non-responsive bid and disqualify the bidder as this data is necessary for determination of installation and operational costs associated with the bid.
- B. This specification describes the physical characteristics and operational requirements. It is not intended to arbitrarily eliminate consideration of alternative systems which may be standard with certain manufacturers. However, the proposed system must be in complete technical compliance with this specification. The manufacturer shall state what, if any, specific points of the proposed system construction and/or operation differ from the following described system.

The Owner reserves the right to reject any design at its own discretion.

- C. The manufacturer shall notify the Owner/Owner and Engineer (Consultant) in writing regarding conflicting requirements, discrepancies or omissions in this specification. Upon written notification, the Owner/Owner and Engineer (Consultant), will resolve all such matters.
- D. If the manufacturer takes exception to any portion of this specification, each exception shall be cross-referenced to its paragraph and page number. All exceptions shall be clearly explained in a section of the proposal defined as "Exceptions to the Specification". If the vendor takes no exception to the specification, the proposal shall so state.
- E. Off-loading, setting in place, installation, interconnecting equipment specified herein shall be the responsibility of the Owner's Contractor (a separate contract and not included in the scope herein) including any and all associated labor, parts, tools and equipment.
- F. It is the intent of this specification for the Owner to pre-purchase the equipment and for it to be assigned to the installing contractor.

1.2 GENERAL REQUIREMENTS

- A. It is the intent of this specification to secure equipment that has been prototype tested, factory built, production tested, site tested, of the latest commercial design, together with all accessories necessary for a complete installation as described in the specifications herein.

1.3 QUALITY ASSURANCE

- A. Bidder's Representative:
 - 1. Each bidder, by making their bid, represents that they have read and understand the bidding documents.

- B. Bidding Procedures:
 - 1. All bids must be prepared and submitted on the forms provided by the Owner.
 - 2. A bid is invalid if it has not been deposited at the designated location prior to the time and date for the receipt of bids indicated or prior to any extension thereof issued to bidders.
 - 3. No bidder shall modify, withdraw, or cancel their bid or any part thereof for sixty (60) days after the time designated for the receipt of bids.
 - 4. Prior to the receipt of bids, bulletins will be mailed or delivered to each person or firm recorded by the Owner as having received the bidding documents and will be available for inspection wherever the bidding documents are kept available for that purpose. Bulletins issued after receipt of bids will be mailed or delivered only to the selected bidder.

- C. Examination of Bidding Documents
 - 1. Any question rose during the bidding period relative to any apparent discrepancies or omissions in the specifications, interpretations of any provisions therein or their intent must be directed only to the Owner.
 - 2. Any and all such answers and interpretations and any other supplemental instructions will be issued to all bidders in the form of written bulletins or letters as the circumstances may require.
 - 3. In order that there may be adequate time for the Owner to properly issue answers and the bidders benefit therefrom, questions must be raised no later than three (3) working days before the bids are due.
 - 4. All bulletins and letters issued during the bidding period shall become part of the Contract Documents, and each bidder shall take their provisions fully into account in the preparation of their proposal.
 - 5. No oral changes to the specifications will be made during the bidding period, and no interpretation obtained in any manner other than as herein before described will be subsequently recognized.
 - 6. Attention is specifically called to the part of the Proposal Form where the bidder shall acknowledge receipt of all bulletins issued and the incorporation in their proposal of the effects thereof.

D. Rejection of Bids:

1. The bidder acknowledges the right of the Owner to reject any and all bids and to waive any informality or irregularity in any bid received. In addition, the bidder recognizes the right of the Owner to reject a bid if the bidder fails to furnish any required bid security, or to submit the data required by the bidding documents, or if the bid is in any way incomplete or irregular.
2. The bidder acknowledges the right of the Owner to reject any portion of the bid received and to award a partial contract based upon the completed proposal.

1.4 SUBMITTALS

A. Shop Drawings:

1. The following drawings and information are to be submitted:
 - a. Detailed specifications and descriptions of equipment to be furnished.
 - b. Physical parameters of size, weight, piping requirements and performance.
 - c. Requirements and extend of field assembly, if necessary.
 - d. Details of items/services to be furnished under this contract and items/services to be furnished by local contractor.
 - e. List of spare parts, where they are stocked, normal delivery time after ordering, and qualified local service organization.
 - f. Delivery schedule (lead time) for all equipment.
 - g. List all deviations from this specification.
 - h. Provide full and part load performance characteristics for equipment.
 - i. Sound performance characteristics.
 - j. Name and phone number of the two (2) nearest service organizations that will have sufficient knowledge to service this equipment.
2. The following drawings and information (8 copies) are to be submitted for review after award of contract:
 - a. Detailed description of all equipment to be furnished, including elevations, dimensions of all equipment, shop drawings and installation drawings.
 - b. Sizes and weight of individual units to be handled in the field.

- c. Complete interconnection, wiring diagrams and details between all components, with external connections identified.
 3. The following drawings and information shall be submitted at the completion of work:
 - a. Five complete sets of operation and maintenance manuals. These manuals shall be applicable to all components of the equipment furnished as part of this specification. The manuals shall include piping diagrams, wiring diagrams, safety precautions, operating and maintenance instructions, installation drawings, list of special tools, and a complete list of numbered replacement parts.
 - b. Spare parts list.
- B. Submission of Post-Bid Information:
 1. Upon request by the Owner, the selected bidder shall submit the following:
 - a. A statement of costs for each major item of work included in the bid.
 - b. A designation of work to be performed by the bidder.
 - c. A list of names of the selected supplier's subcontractors or other persons or organizations. Selected supplier's subcontractors and other persons and organizations proposed by the bidder and accepted by the Owner must be used on the work for which they were proposed and accepted and shall not be changed except with the written approval of the Owner.
- C. Performance Bond and Labor and Material Payment Bond
 1. The Owner shall have the right, prior to the execution of the Contract, to require the bidder to furnish bonds covering the faithful performance of the Contract and the payment of all obligations arising thereunder in such form and amount as the Owner prescribes and with such sureties secured through the bidder's usual sources as may, at their option, withdraw their bid without forfeiture of bid security. If the bidder submits an acceptable substitute with an increase in their bid price to cover the difference in cost occasioned by such substitution, the Owner may, at their discretion, accept the increased bid price or they may disqualify the bidder. Selected supplier's subcontractors and other persons and organizations proposed by the bidder and accepted by the Owner must be used on the work for which they were proposed and accepted and shall not be changed except with the written approval of the Owner.
 2. The bidder shall require the attorney in fact, who executes the required bonds on behalf of the surety, to affix thereto a certified and current copy of their power of attorney, indicating the monetary limit of such power.

1.5 JOB CONDITIONS

- A. Time and Manner
1. The Owner requires that the work be completed as expeditiously as possible.
 2. The time limit, which will be stated by the Owner, will be the essence of the Contract, and the bidder's proposal must be based upon meeting the delivery data therein stated without any additional compensation from the Owner.
 3. The selected supplier shall, therefore, furnish all labor and materials in sufficient quantities, and in ample time, do all the expediting and scheduling of the work required and so manage the operation that the work will be completed within the time stated in the Contract plus any extension thereof approved by the Owner.

PART 2 -

2.1 TEST AND ACCEPTANCE

- A. The operation of the equipment installation does not constitute an acceptance of the work by the Owner. The final acceptance is to be made after the equipment has been adjusted and has demonstrated that it fulfills the requirements of the plans and specifications and supplier has furnished all required documents in accordance with these specifications. A full field performance test including vibration, capacity, controls, etc., shall be performed by the Manufacturer's Representative in the presence of the Engineer upon completion of the installation. Manufacturer shall submit with their bid a recommended test procedure to perform the above.
- B. Upon completion of the installation prior to acceptance, supervise thorough cleaning and adjustment of all apparatus furnished and/or installed under this specification.
- C. Should it be found that the equipment, or any portions thereof, furnished under this section fails to comply with the specifications forming part thereof, with respect or regard to the quality, operation, application, quantity, rating, and performance of materials, appliances or labor used in the work, it shall be rejected and replaced. Cost of all work and changes necessitated in remedy of or replacement of said defects or imperfections shall be borne by the supplier.
- D. After testing, manufacturer shall provide the Owner with the services of a qualified technician for training of the Owner's personnel for a minimum of three (3) working days, two (2) days after the initial on-site tests and one (1) working day approximately six months later.

2.2 WARRANTY

- A. Insurance:
1. Before beginning any work at the site, the Supplier shall furnish certificates, in duplicate, showing coverage for insurance as required by the Owner.
- B. Service Support:

1. Should it become necessary for the presence of a factory-trained service technician to be on site, the Supplier shall provide one at no cost to the Owner within one week after request unless more expeditious response is identified in the respective technical specification any time during construction and before acceptance.

C. Warranty:

1. The manufacturer shall guarantee all equipment and accessories, specified herein, against faulty and improper material and workmanship for the listed period indicated in the associated equipment specification from date of final acceptance by Owner. Provide an add-alternate breakout price for an additional one (1) year guarantee beyond required warranty described above.
2. The manufacturer shall promptly correct all deficiencies in this equipment which occur during the guarantee period, all to the satisfaction of the Owner, at no additional cost to the Owner, including all site labor, transportation and related expenses.
3. If any unit fails to perform during the first thirty days after acceptance by the Owner, the period of warranty shall be extended to two (2) years after the date supplier remedies such failure. The period of warranty shall be similarly extended if that unit fails to perform during a thirty (30) day period after such remedy. The period of warranty shall be similarly extended until the work does not fail for a thirty (30) day period.

2.3 DELIVERY

- A. Delivery of all equipment shall be coordinated with the installing contractor, and scheduled through the Owner. Submit anticipated delivery schedule as part of bid submittal.

END OF SECTION 263213(PPGC)

SECTION 263213(650DEG) – 650 KW DIESEL EMERGENCY GENERATOR**PART 1 - GENERAL****1.1 WORK INCLUDED**

- A. The manufacturer shall provide equipment and services including, but not limited to the following major items (as fully defined later in these specifications):
 - 1. Furnish emergency generator in accordance with Owner's scheduled and 260200 General Conditions Specifications included herewith.
 - 2. All field tests shall be performed in the presence of the Engineer and Owner.
 - 3. Provide on-site technical direction to the electrical contractor by the manufacturer's qualified field personnel, including travel and per-diem expenses at no additional charge.
 - 4. Manufacturer shall include in its bid the delivery of the equipment to the job site loading dock or riggers yard via open top, FOB site, freight prepaid. Delivery to be scheduled at Owner's discretion.
 - 5. 12 months warranty including all remedial labor, to commence with the site acceptance date of the equipment or 18 months from the date of shipment, whichever occurs first.

1.2 SUMMARY

- A. This Section includes packaged engine-generator sets for emergency and standby power supply with the following features:
 - 1. Diesel engine.
 - 2. Unit-mounted cooling system.
 - 3. Unit-mounted control and monitoring.
 - 4. Unit-mounted fuel storage tank.
 - 5. Performance requirements for sensitive loads.
 - 6. Coordination of load banks for testing furnished by Electric Contractor.

1.3 DEFINITIONS

- A. Operational Bandwidth: The total variation from the lowest to highest value of a parameter over the range of conditions indicated, expressed as a percentage of the nominal value of the parameter.

1.4 SUBMITTALS

- A. Shop Drawings: Indicate electrical characteristics and connection requirements. Show plan and elevation views with overall and interconnection point dimensions, fuel consumption rate curves at various loads, ventilation and combustion air requirements, and electrical diagrams including schematic and interconnection diagrams.
- B. Product Data: Provide data showing dimensions, weights, ratings, interconnection points, and internal wiring diagrams for engine, generator, microprocessor control

panel, battery, battery rack, battery charger, exhaust silencer, vibration isolators, fuel tank, trailer and radiator.

- C. Prototype Test Reports: Submittals will not be received without submission of prototype test report as specified herein.
- D. Manufacturer's Installation Instructions: Indicate application conditions and limitations of use stipulated by Product testing agency. Include instructions for storage, handling, protection, examination, preparation, installation, and starting of Product.
- E. Manufacturer's Certificate: Certify that Products meet or exceed specified requirements.
- F. Alternator Data: Indicating sub transient reactance and temperature rise rating to meet requirements specified herein.

1.5 OPERATION AND MAINTENANCE

- A. Manuals: Furnish four (4) Operation and Maintenance manuals.
- B. Operation & Maintenance Data: Include instructions for routine maintenance requirements, service manuals for engine and day tank, oil sampling and analysis for engine wear, and emergency maintenance procedures.

1.6 CODES AND STANDARDS

- A. The generator set installation and on-site testing shall conform to the requirements of the following codes and standards:
 - 1. CSA 282, 1989 Emergency Electrical Power Supply for Buildings.
 - 2. IEEE446 – Recommended Practice for Emergency and Standby Power Systems for Commercial and Industrial Applications.
 - 3. NFPA37
 - 4. NFPA70 – National Electrical Code. Equipment shall be suitable for use in systems in compliance to Article 700, 701, and 702.
 - 5. NFPA110 – Emergency and Standby Power Systems. The generator set shall meet all requirements for Level 1 systems. Level 1 prototype tests required by this standard shall have been performed on a complete and functional unit, component level type tests will not substitute for this requirement.
- B. The generator set and supplied accessories shall meet the requirements of the following standards:
 - 1. NEMA MG1-1998 part 32. Alternator shall comply with the requirements of this standard.
 - 2. UL1236 – Battery Chargers.
 - 3. UL2200. The generator set shall be listed to UL2200 or submit to an independent third party certification process to verify compliance as installed.
 - 4. EPA Emissions Compliance. Engine shall be factory Certified to meet EPA standards for spark ignited engines.

- C. The control system for the generator set shall comply with the following requirements.
1. CSA C22.2, No. 14 – M91 Industrial Control Equipment.
 2. EN50082-2, Electromagnetic Compatibility – Generic Immunity Requirements, Part 2: Industrial.
 3. EN55011, Limits and Methods of Measurement of Radio Interference Characteristics of Industrial, Scientific and Medical Equipment.
 4. FCC Part 15, Subpart B.
 5. IEC8528 part 4. Control Systems for Generator Sets.
 6. IEC Std. 801.2, 801.3, and 801.5 for susceptibility, conducted and radiated electromagnetic emissions.
 7. UL508. The entire control system of the generator set shall be UL508 listed and labeled.
 8. UL1236 –Battery Chargers.

1.7 QUALITY ASSURANCE

- A. To provide proven reliability of the Generator set, three series of tests shall be performed, no exceptions taken:
1. Prototype model tests
 2. Fully assembled factory production model tests
 3. Field acceptance tests
- B. The manufacturer shall provide documentation demonstrating satisfactory prototype and production test results. Generator sets that have not been prototype tested and Factory Production tested as described herein shall not be acceptable.
- C. Generator set Prototype Tests: These tests and evaluations must have been performed on a prototype generator set representative of the model specified. A summary of the generator set testing results shall be submittal for review. The manufacturer's standard series of components development tests on the generator system, engine and other major components shall be performed and available for review, but shall not be acceptable as a substitute for a prototype testing on the complete representative generator set prototype.
- D. Torsiograph Analysis and Test: The manufacturer of the generator set shall verify that the engine generator set, as configured, is free from harmful torsional stresses. The analysis shall include correlation of empirical data from tests on a representative prototype. The empirical data must include spectrum analysis of the torsional transducer output within the operating speed range of the engine generator set. Calculations based on engine and generator separately are not acceptable.
- E. Temperature Rise Test: Complete thermal evaluation of a prototype generator rotor and starter must include actual measurement of internal generator and exciter temperatures by embedded detector method, and measurement of average temperature rise by resistance method. No position measured any place in the windings may exceed the temperature rise limits of NEMA for the particular type of insulation system used. Resistance method temperature rise data shall be confirmed by a full load test on the generator set prototype to include conducted and radiated heat from the engine. A calculated temperature rise method shall also be acceptable.

- F. Short Circuit Test: A test on a prototype generator set shall have demonstrated that the generator set is designed to withstand the mechanical forces associated with a short circuit condition. With the generator set operating at rated load and speed, the generator terminals must be short circuited on all three phases for duration of 20 seconds. At the conclusion of this test, the generator set must be capable of full load operation.
- G. Endurance Run Test: A minimum of 500 continuous hours of endurance testing with a representative generator set prototype operating as defined by the manufacturer's standby rating shall have been performed. Endurance testing shall be used to verify structural soundness and durability.
- H. Maximum Power Test: With the prototype generator set at normal operating temperature and with all power consuming auxiliaries in place, the maximum power available at rated speed shall be determined with the governor set at its fuel stop. The generator set shall maintain this power for a minimum of two (2) minutes.
- I. Linear Vibration Test: A test for in-line motion of components occurring along a repeatable path shall meet the manufacturer's acceptable criteria.
- J. Cooling System Test: A cooling system test shall demonstrate the ability of the generator set cooling system to maintain normal operating temperature while operating at full rated load and power factor at the highest ambient temperature (104 °F) of the system rating. Cooling air requirements, radiator air flow and maximum allowable restriction at radiator discharge shall be verified by this test.
- K. Maximum Motor Starting KVA Test: Motor starting KVA shall be determined by test, based on a sustained RMS recovery voltage of at least 90 percent on no load voltage with the specified load KVA at near zero power factor applied to the generator set. An instantaneous motor starting calculated method shall be allowable.
- L. Transient Response, Steady State Speed Control and Voltage Regulation Test: Prototype generator set tests shall demonstrate consistent performance as follows; stable voltage and frequency at all loads from no load to full rated load, consistent frequency kp on load acceptance and rejection and restoration to steady state after sudden load changes. Transient response is a complete generator set (engine, generator, exciter, and regulator) performance criteria and cannot be established on generator data alone.
- M. Witness-Generator Set Factory Production Tests: On the equipment to be shipped, an eight-(8) hour test shall be performed at rated load and 0.8 PF. These tests shall include certified data to document the following: run at full load, maximum power, voltage regulation, transient and steady state governing, single step load pickup and safety shutdowns. Provide a factory test record of the production testing. The Contractor and/or equipment supplier at their expense shall coordinate and provide all transportation and lodging for the owner and Owner's engineering representative to witness the above stated factory test.
- N. Factory Test: The unit shall completely assembled and all preliminary adjustments made before the test is initiated.

- O. Testing Procedure:
1. Test diesel-alternator unit at 0.8 PF in the following sequence:
 2. 0.5 hour at $\frac{1}{4}$ load.
 3. 0.5 hours at $\frac{1}{2}$ load.
 4. 0.5 hours at $\frac{3}{4}$ load.
 5. 0.5 hours at full load.
- P. Above testing shall be strip chart recorded and certified. During this test, the following measurements shall be taken and recorded on a certified report format:
1. Barometric Pressure.
 2. Intake Air Pressure.
 3. RPM.
 4. Output voltage per phase.
 5. Output amperes per phase.
 6. Power Factor.
 7. KW.
 8. Transient response testing sequence:
 9. 0-25%, 25%-0.
 10. 0-50%, 50%-0.
 11. 0-75%, 75%-0.
 12. 0-100%, 100%-0.
- Q. Above testing shall be strip chart recorded. Provide necessary equipment and instruments to measure voltage dips and frequency dips. Comparison shall be made to the herein specified alternator performance characteristics prior to acceptance.
- R. Field Acceptance Tests: Generator supplier shall provide and conduct a four (4) hour load bank test at unity power factor for the generator set. Contractor shall provide portable load bank for testing generator set at 100% load. Load bank test shall test each generator at full nameplate KW ratings. Generator manufacturer's representative shall record test data, as described below. Test data shall be tabulated and typed for submission and approval by the engineer for final acceptance. No handwritten field notes will be allowed.
- S. Initial startup and field acceptance tests are to be conducted by the authorized representative of the system manufacturer who supplies the equipment. Contractor responsible for protection of testing equipment and any additional cable, etc., required if equipment cannot be located internally during testing.
- T. Test data shall be collected and recorded on the following: Time of day, coolant temperature, operating oil pressure, battery charging rate, cranking time, crank-to-rated frequency time, voltage and frequency overshoot, load assumption-to-steady state voltage and frequency stabilization time, operating voltage, frequency, current, kilowatts and power factor. All data shall be taken every fifteen (15) minutes.

1.8 QUALIFICATIONS

- A. Manufacturer: Company specializing in manufacturing the Products specified in this section with minimum ten (10) years documented experience, and with an authorized

distributor offering 24 hour parts and service availability within 50 miles of the project. Proposed engine/generator combination shall have been in production a minimum of five (5) years.

- B. Supplier: Authorized distributor of specified manufacturer with minimum five (5) years documented experience with specified products and factory-trained service technicians.

1.9 REGULATORY REQUIREMENTS

- A. Conform to requirements of NFPA 70, NFPA 110.
- B. Furnish Products listed and classified by Underwriters Laboratories as suitable for purpose specified and indicated.

1.10 PRE-INSTALLATION CONFERENCE

- A. Convene one (1) week prior to commencing work of this Section.

1.11 DELIVERY, STORAGE, AND HANDLING

- A. Deliver, store, protect and handle products in accordance with factory standards and 263213 General Conditions Specifications.

1.12 EXTRA MATERIALS

- A. Provide two (2) of each oil and air filter element, engine belts and hoses.

1.13 WARRANTY

- A. A comprehensive warranty shall be provided for all products against defects in materials and workmanship for a five-year or 1500 hour period from date of final acceptance by Owner. Warranty shall cover all costs of covered repairs, including travel expenses. Refer to 263213 General Conditions Specifications for additional requirements.

1.14 SERVICE AGREEMENT

- A. Manufacturer shall provide Owner with a one (1) year service agreement from the start-up date that includes changing all fluids and filters once a year and a minor inspection six (6) months after each change.

PART 2 - PRODUCTS

2.1 MANUFACTURERS

- A. Manufacturers: Subject to compliance with requirements, provide products by one of the following:
 1. Kinsley Power Systems, 14 Connecticut South Drive, East Cranby, CT 06026
Contact; Mr. Richard Cupillo, 860-8444-2220 (Cell 860-930-3479)

2. MTU Onsite Energy; By Atlantic Power Systems, Middletown, CT, 06457.
Contact; Mr. Michael Wynne, 860-632-0218 (Cell 860-913-4256).
3. Caterpillar; By H.O. Penn Machinery, Newington, CT, 06111.
Contact; Mr. John Stroh, 860-666-8401 (Cell 203-410-4333).
4. Cummins/Onan; By Cummins Power System, Rocky Hill, CT, 06067.
Contact; Mr. Michael Ruttly, 860-721-2240 (Cell 860-558-8888).

B. Manufacturers Models: Subject to compliance with requirements, provide models as follows:

1. Kohler; Model 600REOZVB.
2. MTU Onsite Energy; Model 650DSEB Series.
3. Caterpillar; Model C27 ACERT Series.
4. Cummins/Onan; Model 750DQCB Series.

2.2 DIESEL ENGINE-GENERATOR SET

A. Ratings

1. The generator set shall operate at 1800 rpm and at a voltage of: 480 Volts AC, 3-phase, 4-wire, 60 hertz.
2. The generator set shall be rated at 650KW/813kVA at 0.8 PF, standby rating, based on site conditions of altitude 1000 ft. and ambient temperatures up to 104°F-134°F (40°C-54°C).

B. Performance

1. Voltage regulation shall be plus or minus 0.5 percent for any constant load between no load and rated load. Random voltage variation with any steady load from no load to full load shall not exceed plus or minus 0.5 percent.
2. Frequency regulation shall be isochronous from steady state no load to steady state rated load. Random frequency variation with any steady load from no load to full load shall not exceed plus or minus 0.25%.
3. The engine-generator set shall accept a single step load of 100% nameplate kW and power factor, less applicable derating factors, with the engine-generator set at operating temperature.
4. Motor starting capability shall be a minimum of 1750KVA at 35% voltage dip. Upon application of 100% block load, generator set shall recover to rated voltage and frequency in 0-4 seconds at 0.8PF.
5. The alternator shall produce a clean AC voltage waveform, with not more than 5% total harmonic distortion at full linear load, when measured from line to neutral, and with not more than 3% in any single harmonic, and no 3rd order harmonics or their multiples. Telephone influence factor shall be less than 40.
6. The generator set shall be certified by the engine manufacturer to be suitable for use at the installed location and rating, and shall meet all applicable exhaust emission requirements at the time of commissioning.

C. Construction

1. The engine-generator set shall be mounted on a heavy-duty steel base to maintain alignment between components. The base shall incorporate a battery tray with hold-down clamps within the rails.
2. All switches, lamps, and meters in the control system shall be oil-tight and dust-tight. All active control components shall be installed within a UL/NEMA 3R enclosure. There shall be no exposed points in the control (with the door open) that operate in excess of 50 volts.

D. Connections

1. The generator set load connections shall be composed of silver or tin plated copper bus bars, drilled to accept mechanical or compression terminations of the number and type as shown on the drawings. Sufficient lug space shall be provided for use with cables of the number and size as shown on the drawings.
2. Power connections to auxiliary devices shall be made at the devices with required protection located at a wall-mounted common distribution panel (If walk-in enclosure).
3. Generator set control interfaces to other system components shall be made on a permanently labeled terminal block assembly. Labels describing connection point functions shall be provided.

2.3 ENGINE AND ENGINE EQUIPMENT

- A. The engine shall be diesel, 4 cycle, radiator and fan cooled. It shall be EPA Emissions Certified. Provide catalyst and muffler system to be internally factory mounted inside sound enclosure. The horsepower rating of the engine at its minimum tolerance level shall be sufficient to drive the alternator and all connected accessories. Two cycle engines are not acceptable.
- B. Complete engine fuel system, including all pressure regulators, strainers, and control valves. The fuel system shall be plumbed to the generator set skid for ease of site connections to the generator set. For dual fuel systems, changeover from primary to secondary fuel shall be automatic. An electronic governor system shall provide automatic isochronous frequency regulation. The governing system dynamic capabilities shall be controlled as a function of engine coolant temperature to provide fast, stable operation at varying engine operating temperature conditions. The control system shall actively control the fuel rate and excitation as appropriate to the state of the generator set. Fuel rate shall be regulated as a function of starting, accelerating to start disconnects speed, accelerating to rated speed, and operating in various isochronous or parallel states.
- C. Skid-mounted radiator and cooling system rated for full load operation in 104°F (40°C) ambient as measured at the alternator air inlet. Radiator fan shall be suitable for use in a system with 0.5 in H₂O restriction. Radiator shall be sized based on a core temperature that is 16°F-20°F higher than the rated operation temperature, or prototype tested to verify cooling performance of the engine/radiator/fan operation in a controlled environment. Radiator shall be provided with a duct adapter flange. The equipment manufacturer shall fill the cooling system with a 50/50-ethylene glycol/water mixture prior to shipping. Rotating parts shall be guarded against accidental electric starter(s) capable of three complete cranking cycles without overheating.

2.4 ENGINE ACCESSORY EQUIPMENT

- A. The engine for the generator shall include the following accessories:
1. Positive displacement, contact.
 2. Mechanical, full pressure, lubrication oil pump.
 3. Full flow lubrication oil filters with replaceable spin-on canister elements and dipstick oil level indicator.
 4. Replaceable dry element air cleaner with restriction indicator.
 5. Flexible supply and return fuel lines.
 6. Engine mounted battery charging alternator, 24 Volts DC, 70-ampere minimum, and solid-state voltage regulator.
- B. Coolant heater
1. Engine mounted thermostatically controlled, coolant heater for each engine. Heater voltage shall be as shown on the project drawings. The coolant heater shall be UL499 listed and labeled.
 2. The coolant heater shall be installed on the engine with silicone hose connections. The coolant heater installation shall be specifically designed to provide proper venting of the system. The coolant heaters shall provisions to isolate the heater for replacement of the heater element without draining the coolant from the generator set. The quick disconnect/automatic sealing couplers shall allow the heater element to be replaced without draining the engine cooling system or significant coolant loss.
 3. The coolant heater shall be provided with a 24VDC thermostat, installed at the engine thermostat housing. An AC power connection box shall be provided for a single AC power connection to the coolant heater system.
 4. The coolant heater(s) shall be sized as recommended by the engine manufacturer to warm the engine to a minimum of 104°F (40°C) in a 40°F (4°C) ambient, in compliance with NFPA110 requirements, or the temperature required for starting and load pickup requirements of this specification.
- C. Provide vibration isolators, spring/pad type, quantity as recommended by the generator set manufacturer. Isolators shall include seismic restraints rated for zone area and have bonded 1/4-inch- thick elastomeric isolator pad attached to baseplate underside.
- D. Starting and Control Batteries shall be calcium/lead antimony type, 12 volt DC, sized as recommended by the engine manufacturer, complete with battery cables and connectors. The batteries shall be capable of a minimum of three complete 15-second cranking cycles at 40 deg. F ambient temperature when fully charged.
- E. Provide exhaust silencer for each engine of size and type as recommended by the generator set manufacturer and approved by the engine manufacturer. The mufflers shall be critical grade. Provide Catalyst system as required to meet EPA standards. Muffler and Catalyst shall be internally mounted inside sound enclosure by generator manufacturer.
- F. A UL listed/CSA certified 10-12 amp voltage regulated battery charger shall be provided for each engine-generator set. Input AC voltage and DC output voltage shall be as required. Chargers shall be equipped with float, taper and equalize charge

settings. Operational monitors shall provide visual output along with individual form C contacts rated at 4 amps, 120 VAC, 30VDC for remote indication of:

1. Loss of AC power - red light
 2. Low battery voltage - red light
 3. High battery voltage - red light
 4. Power ON - green light (no relay contact)
- G. Charger shall include an Analog DC voltmeter and ammeter, 12 hour equalizing charge timer, and AC and DC fuses.

2.5 AC ALTERNATOR

- A. The AC generator shall be; synchronous, four pole, 2/3 pitch, revolving field, drip-proof construction, single pre lubricated sealed bearing, air cooled by a direct drive centrifugal blower fan, and directly connected to the engine with flexible drive disc. All insulation system components shall meet NEMA MG1 temperature limits for Class H insulation system and shall be UL1446 listed. Actual temperature rise measured by resistance method at full load shall not exceed 105°C.
- B. The generator shall be capable of delivering rated output (kVA) at rated frequency and power factor, at any voltage not more than 5 percent above or below rated voltage.
- C. A permanent magnet generator (PMG) shall be included to provide a reliable source of excitation power for optimum motor starting and short circuit performance. The PMG and controls shall be capable of sustaining and regulating current supplied to a single phase or three phase fault at approximately 300% of rated current for not more than 10 seconds.
- D. The sub-transient reactance of the alternator shall not exceed 12%-14%, based on a not to exceed 105°C rise rating.

2.6 ENGINE GENERATOR SET CONTROL

- A. Generator Set Control. The generator set shall be provided with a microprocessor-based control system that is designed to provide automatic starting, monitoring, and control functions for the generator set. The control system shall also be designed to allow local monitoring and control of the generator set, and remote monitoring and control as described in this specification.
- B. The control shall be mounted on the generator set, or may be mounted in a free-standing panel next to the generator set if adequate space and accessibility is available. The control shall be vibration isolated and prototype tested to verify the durability of all components in the system under the vibration conditions encountered.
- C. Control Switches
1. Mode Select Switch. The mode select switch shall initiate the following control modes. When in the RUN or MANUAL position the generator set shall start, and accelerate to rated speed and voltage as directed by the operator. A separate push-button to initiate starting is acceptable. In the OFF position the generator

set shall immediately stop, bypassing all time delays. In the AUTO position the generator set shall be ready to accept a signal from a remote device to start and accelerate to rated speed and voltage.

2. EMERGENCY STOP switch. Switch shall be Red "mushroom-head" push-button. Depressing the emergency stop switch shall cause the generator set to immediately shut down, and be locked out from automatic restarting.
3. RESET switch. The RESET switch shall be used to clear a fault and allow restarting the generator set after it has shut down for any fault condition.
4. PANEL LAMP switch. Depressing the panel lamp switch shall cause the entire panel to be lighted with DC control power. The panel lamps shall automatically be switched off 10 minutes after the switch is depressed, or after the switch is depressed a second time.

D. Generator Set AC Output Metering. The generator set shall be provided with a metering set including the following features and functions:

1. Digital metering set, 1% accuracy, to indicate generator RMS voltage and current, frequency, output current, output KW, KW-hours, and power factor. Generator output voltage shall be available in line-to-line and line-to-neutral voltages, and shall display all three-phase voltages (line to neutral or line to line) simultaneously.
2. The control system shall monitor the total load on the generator set, and maintain data logs of total operating hours at specific load levels ranging from 0 to 110% of rated load, in 10% increments. The control shall display hours of operation at less than 30% load and total hours of operation at more than 90% of rated load.
3. The control system shall log total number of operating hours, total KWH, and total control on hours, as well as total values since reset.

E. Generator Set Alarm and Status Display.

1. The generator set control shall include LED alarm and status indication lamps. The lamps shall be high-intensity LED type. The lamp condition shall be clearly apparent under bright room lighting conditions. Functions indicated by the lamps shall include:
2. The control shall include five configurable alarm-indicating lamps. The lamps shall be field adjustable for any status, warning, or shutdown function monitored by the generator set. They shall also be configurable for color, and control action (status, warning, or shutdown).
 - a. The control shall include green lamps to indicate that the generator set is running at rated frequency and voltage, and that a remote start signal has been received at the generator set. The running signal shall be based on actual sensed voltage and frequency on the output terminals of the generator set.
 - b. The control shall include a flashing red lamp to indicate that the control is not in automatic state, and red common shutdown lamp.
 - c. The control shall include an amber common warning indication lamp.
3. The generator set control shall indicate the existence of the warning and shutdown conditions on the control panel. All conditions indicated below for

warning shall be field-configurable for shutdown. Conditions required to be annunciated shall include:

- a. Low oil pressure (warning)
 - b. Low oil pressure (shutdown)
 - c. Oil pressure sender failure (warning)
 - d. Low coolant temperature (warning)
 - e. High coolant temperature (warning)
 - f. High coolant temperature (shutdown)
 - g. High oil temperature (warning)
 - h. Engine temperature sender failure (warning)
 - i. Low coolant level (warning)
 - j. Fail to crank (shutdown)
 - k. Fail to start/overcrank (shutdown)
 - l. Overspeed (shutdown)
 - m. Low DC voltage (warning)
 - n. High DC voltage (warning)
 - o. Weak battery (warning)
 - p. Low fuel-day tank (warning)
 - q. High AC voltage (shutdown)
 - r. Low AC voltage (shutdown)
 - s. Under frequency (shutdown)
 - t. Over current (warning)
 - u. Over current (shutdown)
 - v. Short circuit (shutdown)
 - w. Overload (warning)
 - x. Emergency stop (shutdown)
 - y. (4) configurable conditions
4. Provisions shall be made for indication of four customer-specified alarm or shutdown conditions. Labeling of the customer-specified alarm or shutdown conditions shall be of the same type and quality as the above-specified conditions. The non-automatic indicating lamp shall be red, and shall flash to indicate that the generator set is not able to automatically respond to a command to start from a remote location.

F. Engine Status Monitoring.

1. The following information shall be available from a digital status panel on the generator set control:
 - a. Engine oil pressure (psi or kPA)
 - b. Engine coolant temperature (degrees F or C)
 - c. Engine oil temperature (degrees F or C)
 - d. Engine speed (rpm)
 - e. Number of hours of operation (hours)
 - f. Number of start attempts
 - g. Battery voltage (DC volts)
2. The control system shall also incorporate a data logging and display provision to allow logging of the last 10 warning or shutdown indications on the generator set,

as well as total time of operation at various loads, as a percent of the standby rating of the generator set.

2.7 ENGINE CONTROL FUNCTIONS

- A. The control system provided shall include a cycle cranking system, which allows for user selected crank time, rest time, and # of cycles. Initial settings shall be for 3 cranking periods of 15 seconds each, with 15-second rest period between cranking periods.
- B. The control system shall include an idle mode control, which allows the engine to run in idle mode in the RUN position only. In this mode, the alternator excitation system shall be disabled. Total duration of operating time in the idle mode shall be controlled by the system, to prevent degradation of the engine capabilities due to excess operating time at idle.
- C. The control system shall include an engine governor control, which functions to provide steady state frequency regulation as noted elsewhere in this specification. The governor control shall include adjustments for gain, damping, and a ramping function to control engine speed and limit exhaust smoke while the unit is starting.
- D. The control system shall include time delay start (adjustable 0-300 seconds) and time delay stop (adjustable 0-600 seconds) functions.
- E. The control system shall include sender failure monitoring logic for speed sensing, oil pressure, and engine temperature which is capable of discriminating between failed sender or wiring components, and actual failure conditions.

2.8 ALTERNATOR CONTROL FUNCTIONS

- A. The generator set shall include a full wave rectified automatic digital voltage regulation system that is matched and prototype tested by the engine manufacturer with the governing system provided. It shall be immune from misoperation due to load-induced voltage waveform distortion and provide a pulse width modulated output to the alternator exciter. The voltage regulation system shall be equipped with three-phase line to neutral RMS sensing and shall control buildup of AC generator voltage to provide a linear rise and limit overshoot. The system shall include a torque-matching characteristic, which shall reduce output voltage in proportion to frequency below an adjustable frequency threshold. Torque matching characteristic shall be adjustable for roll-off frequency and rate, and be capable of being curve-matched to the engine torque curve with adjustments in the field. The voltage regulator shall include adjustments for gain, damping, and frequency roll-off. Adjustments shall be broad range, and made via digital raise-lower switches, with an alphanumeric LED readout to indicate setting level. Rotary potentiometers for system adjustments are not acceptable.
- B. Controls shall be provided to monitor the output current of the generator set and initiate an alarm (over current warning) when load current exceeds 110% of the rated current of the generator set on any phase for more than 60 seconds. The controls shall shut down and lock out the generator set when output current level approaches the thermal

damage point of the alternator (over current shutdown). The protective functions provided shall be in compliance to the requirements of NFPA70 article 445.

- C. Controls shall be provided to individually monitor all three phases of the output current for short circuit conditions. The control/protection system shall monitor the current level and voltage. The controls shall shut down and lock out the generator set when output current level approaches the thermal damage point of the alternator (short circuit shutdown). The protective functions provided shall be in compliance to the requirements of NFPA70 Article 445.
- D. An AC over/under voltage monitoring system that responds only to true RMS voltage conditions shall be provided. The system shall initiate shutdown of the generator set when alternator output voltage exceeds 110% of the operator-set voltage level for more than 10 seconds, or with no intentional delay when voltage exceeds 130%. Under voltage shutdown shall occur when the output voltage of the alternator is less than 85% for more than 10 seconds.

2.9 OTHER CONTROL FUNCTIONS

- A. A battery monitoring system shall be provided which initiates alarms when the DC control and starting voltage is less than 25VDC or more than 32 VDC. During engine cranking (starter engaged), the low voltage limit shall be disabled, and DC voltage shall be monitored as load is applied to the battery, to detect impending battery failure or deteriorated battery condition.

2.10 FUEL STORAGE TANK

- A. Comply with NFPA 30.
- B. Sub-Base Tank: Comply with UL 142, fuel tank assembly, with the following features:
 1. Containment: Integral rupture basin with a capacity of 110% of nominal capacity of tank.
 2. Leak Detector: Locate in rupture basin and connect to provide audible and visual alarm in the event of tank leak.
 3. Tank Capacity: 72 hours at 100% load.
 4. Pump Capacity: Exceeds maximum flow of fuel drawn by engine-mounted fuel supply pump at 110 percent of rated capacity, including fuel returned from engine.
 5. Low-Level Alarm Sensor: Liquid-level device operates alarm contacts at 25 percent of normal fuel level.
 6. High-Level Alarm Sensor: Liquid-level device operates alarm and redundant fuel shutoff contacts at midpoint between overflow level and 100 percent of normal fuel level.

2.11 GENERATOR ACCESSORIES

- A. The generator set shall be provided with a set mounted two (2) molded case 65,000AIC main line circuit breakers. The circuit breakers shall be 100% rated solid state electronic type with long, short, instantaneous (LSI) trip features. Unit shall protect the alternator under all overcurrent conditions. The supplier shall submit time

overcurrent characteristic curves and thermal damage curve for the alternator, demonstrating the effectiveness of the protection provided. The supplier shall also take responsibility to provide the proper microprocessor trip unit and LSI settings in the mainline breaker that will selectively coordinate with all downstream emergency distribution overcurrent protective devices directly connected.

- B. Provide one serial Modbus RS-485 Network Card. Provide start-up/programming and mapping register for IT support to enter mapping points via Modbus.
- C. Remote Alarm Annunciator: Comply with NFPA 99. An LED labeled with proper alarm conditions shall identify each alarm event and a common audible signal shall sound for each alarm condition. Silencing switch in face of panel shall silence signal without altering visual indication. Connect so that after an alarm is silenced, clearing of initiating condition will reactivate alarm until silencing switch is reset.

2.12 SKIN-TIGHT SOUND ENCLOSURE

- A. Sound Attenuation: Enclosure shall not exceed 75dBA @ 23ft. Entire assembly shall be able to reduce generator set noise in free field to listed attenuation at distance in any direction.
- B. Steel Skin: Enclosure to be covered with finished marine grade steel panels. Include cost for custom color as selected by Owner. Covering to be separated from structural steel with 1/8" closed cell rubber foam insulation. All fasteners to be made of non-corrosive materials. All panel fasteners will not be visible on the exterior. Roof panel joints to have continuous covers, sealed and secured to steel frame with corrosion resistant fasteners.
- C. Accessories: Muffler brackets to be solid aluminum structural angle, welded as one piece for internal installation from a super critical sound absorber muffler. Muffler straps provided to be custom fit for the muffler. Insulation for interior muffler/flex and exhaust pipe provided and installed. Aluminum rain caps and collars made to prevent rain intrusion at roof penetration. Engine oil and water drains to be extended to exterior of enclosure.
- D. Base Description: Built from 7 gauge steel plate, 12" channel, and 7 gauge steel floor with electrical stub up areas. Provide 4 point lift rings, prime and painted with black enamel.
- E. Electrical Accessories:
 - 1. Junction box for ancillary components requiring field circuitry.
 - 2. Duplex receptacle(s).
 - 3. Remote weatherproof emergency stop switch.

PART 3 - EXECUTION

3.1 EXAMINATION

- A. Examine areas, equipment bases, and conditions, with Installer present, for compliance with requirements for installation and other conditions affecting packaged engine-generator performance.
- B. Examine roughing-in of piping systems and electrical connections. Verify actual locations of connections before packaged engine-generator installation.
- C. Proceed with installation only after unsatisfactory conditions have been corrected.

3.2 INSTALLATION

- A. Coordinate with Electric Contractor the packaged engine-generator manufacturers' written installation and alignment instructions and with NFPA 110.
- B. Coordinate with Electric Contractor for installation of packaged engine generator to provide access, without removing connections or accessories, for periodic maintenance.
- C. Coordinate with Electric Contractor for installation of packaged engine generator with restrained spring isolators having a minimum deflection of 1 inch on 4-inch- high concrete base. Contractor to secure set to anchor bolts installed in concrete bases.
- D. Electrical Wiring: Coordinate with Electric Contractor electrical devices furnished by equipment manufacturers but not specified to be factory mounted.

3.3 FIELD QUALITY CONTROL

- A. Perform tests and inspections and prepare test reports.
 - 1. Manufacturer's Field Service: Provide a factory-authorized service representative to inspect components, assemblies, and equipment installations, including connections, and to assist Electric Contractor in testing.
- B. Tests and Inspections:
 - 1. Tests shall be as recommended by manufacturer's factory engineer and each electrical test and visual and mechanical inspection (except those indicated to be optional) for "AC Generators and for Emergency Systems" specified in NETA Acceptance Testing Specification. Certify compliance with test parameters.
 - 2. Building Load Test: Electric Contractor to perform after set is installed.
 - 3. Battery Tests: Electric Contractor to equalize charging of battery cells according to manufacturer's written instructions. Record individual cell voltages.
 - a. Measure charging voltage and voltages between available battery terminals for full-charging and float-charging conditions. Check electrolyte level and specific gravity under both conditions.
 - b. Test for contact integrity of all connectors. Perform an integrity load test and a capacity load test for the battery.
 - c. Verify acceptance of charge for each element of the battery after discharge.
 - d. Verify that measurements are within manufacturer's specifications.

4. Battery-Charger Tests: Electric Contractor to verify specified rates of charge for both equalizing and float-charging conditions.
 5. System Integrity Tests: Electric Contractor to methodically verify proper installation, connection, and integrity of each element of engine-generator system before and during system operation. Check for air, exhaust, and fluid leaks.
 6. Exhaust Emissions Test: Electric Contractor to comply with applicable State and Local Government test criteria.
- C. Coordinate tests with tests for transfer switches and run them concurrently.
- D. Leak Test: After installation, Electric Contractor to charge system and test for leaks. Repair leaks and retest until no leaks exist.
- E. Operational Test: After electrical circuitry has been energized, Electric Contractor to start units to confirm proper motor rotation and unit operation.
- F. Test and adjust controls and safeties. Replace damaged and malfunctioning controls and equipment.
- G. Remove and replace malfunctioning units and retest as specified above.
- H. Retest: Correct deficiencies identified by tests and observations and retest until specified requirements are met.
- I. Report results of tests and inspections in writing. Record adjustable relay settings and measured insulation resistances, time delays, and other values and observations. Attach a label or tag to each tested component indicating satisfactory completion of tests.
- J. Infrared Scanning: After Substantial Completion, but not more than 60 days after Final Acceptance, Electric Contractor to perform an infrared scan of each power wiring termination and each bus connection. All access panels shall be removed so terminations and connections are accessible to portable scanner.
1. Follow-up Infrared Scanning: Perform an additional follow-up infrared scan 11 months after date of Substantial Completion.
 2. Instrument: Use an infrared scanning device designed to measure temperature or to detect significant deviations from normal values. Provide calibration record for device.
 3. Record of Infrared Scanning: Prepare a certified report that identifies terminations and connections checked and that describes scanning results. Include notation of deficiencies detected, remedial action taken and observations after remedial action.

3.4 ACCEPTANCE

- A. Equipment shall be initially started and operated by representatives of the manufacturer.

- B. All equipment shall be physically inspected for damage. Scratches and other installation damage shall be repaired prior to final system testing. Equipment shall be thoroughly cleaned to remove all dirt and construction debris prior to final testing of the system.

3.5 TRAINING

- A. The equipment supplier shall provide training for the facility operating personnel covering operation and maintenance of the equipment provided. The training program shall be not less than two (2) four (4) hours sessions in duration and the class size shall be limited to five (5) persons. Training date shall be coordinated with the facility owner.

3.6 DEMONSTRATION

- A. The equipment supplier shall train Owner's maintenance personnel to adjust, operate, and maintain packaged engine generators.
- B. Electric Contractor shall provide fuel for testing and shall fill tank complete after all testing is done and before turning over to Owner.
- C. Describe loads connected to standby system and restrictions for future load additions.
- D. Simulate power outage by interrupting normal source, and demonstrate that system operates to provide standby power.

END OF SECTION 263213(DEG)

SECTION 263213(1250DEG) – 1250 KW DIESEL EMERGENCY GENERATOR**PART 1 - GENERAL****1.1 WORK INCLUDED**

- A. The manufacturer shall provide equipment and services including, but not limited to the following major items (as fully defined later in these specifications):
1. Furnish emergency generator in accordance with Owner's scheduled and 260200 General Conditions Specifications included herewith.
 2. All field tests shall be performed in the presence of the Engineer and Owner.
 3. Provide on-site technical direction to the electrical contractor by the manufacturer's qualified field personnel, including travel and per-diem expenses at no additional charge.
 4. Manufacturer shall include in its bid the delivery of the equipment to the job site loading dock or riggers yard via open top, FOB site, freight prepaid. Delivery to be scheduled at Owner's discretion.
 5. 12 months warranty including all remedial labor, to commence with the site acceptance date of the equipment or 18 months from the date of shipment, whichever occurs first.

1.2 SUMMARY

- A. This Section includes packaged engine-generator sets for emergency and standby power supply with the following features:
1. Diesel engine.
 2. Unit-mounted cooling system.
 3. Unit-mounted control and monitoring.
 4. Unit-mounted fuel storage tank.
 5. Performance requirements for sensitive loads.
 6. Coordination of load banks for testing furnished by Electric Contractor.

1.3 DEFINITIONS

- A. Operational Bandwidth: The total variation from the lowest to highest value of a parameter over the range of conditions indicated, expressed as a percentage of the nominal value of the parameter.

1.4 SUBMITTALS

- A. Shop Drawings: Indicate electrical characteristics and connection requirements. Show plan and elevation views with overall and interconnection point dimensions, fuel consumption rate curves at various loads, ventilation and combustion air requirements, and electrical diagrams including schematic and interconnection diagrams.
- B. Product Data: Provide data showing dimensions, weights, ratings, interconnection points, and internal wiring diagrams for engine, generator, microprocessor control

panel, battery, battery rack, battery charger, exhaust silencer, vibration isolators, fuel tank, trailer and radiator.

- C. Prototype Test Reports: Submittals will not be received without submission of prototype test report as specified herein.
- D. Manufacturer's Installation Instructions: Indicate application conditions and limitations of use stipulated by Product testing agency. Include instructions for storage, handling, protection, examination, preparation, installation, and starting of Product.
- E. Manufacturer's Certificate: Certify that Products meet or exceed specified requirements.
- F. Alternator Data: Indicating sub transient reactance and temperature rise rating to meet requirements specified herein.

1.5 OPERATION AND MAINTENANCE

- A. Manuals: Furnish four (4) Operation and Maintenance manuals.
- B. Operation & Maintenance Data: Include instructions for routine maintenance requirements, service manuals for engine and day tank, oil sampling and analysis for engine wear, and emergency maintenance procedures.

1.6 CODES AND STANDARDS

- A. The generator set installation and on-site testing shall conform to the requirements of the following codes and standards:
 - 1. CSA 282, 1989 Emergency Electrical Power Supply for Buildings.
 - 2. IEEE446 – Recommended Practice for Emergency and Standby Power Systems for Commercial and Industrial Applications.
 - 3. NFPA37
 - 4. NFPA70 – National Electrical Code. Equipment shall be suitable for use in systems in compliance to Article 700, 701, and 702.
 - 5. NFPA110 – Emergency and Standby Power Systems. The generator set shall meet all requirements for Level 1 systems. Level 1 prototype tests required by this standard shall have been performed on a complete and functional unit, component level type tests will not substitute for this requirement.
- B. The generator set and supplied accessories shall meet the requirements of the following standards:
 - 1. NEMA MG1-1998 part 32. Alternator shall comply with the requirements of this standard.
 - 2. UL1236 – Battery Chargers.
 - 3. UL2200. The generator set shall be listed to UL2200 or submit to an independent third party certification process to verify compliance as installed.
 - 4. EPA Emissions Compliance. Engine shall be factory Certified to meet EPA standards for spark ignited engines.

- C. The control system for the generator set shall comply with the following requirements.
1. CSA C22.2, No. 14 – M91 Industrial Control Equipment.
 2. EN50082-2, Electromagnetic Compatibility – Generic Immunity Requirements, Part 2: Industrial.
 3. EN55011, Limits and Methods of Measurement of Radio Interference Characteristics of Industrial, Scientific and Medical Equipment.
 4. FCC Part 15, Subpart B.
 5. IEC8528 part 4. Control Systems for Generator Sets.
 6. IEC Std. 801.2, 801.3, and 801.5 for susceptibility, conducted and radiated electromagnetic emissions.
 7. UL508. The entire control system of the generator set shall be UL508 listed and labeled.
 8. UL1236 –Battery Chargers.

1.7 QUALITY ASSURANCE

- A. To provide proven reliability of the Generator set, three series of tests shall be performed, no exceptions taken:
1. Prototype model tests
 2. Fully assembled factory production model tests
 3. Field acceptance tests
- B. The manufacturer shall provide documentation demonstrating satisfactory prototype and production test results. Generator sets that have not been prototype tested and Factory Production tested as described herein shall not be acceptable.
- C. Generator set Prototype Tests: These tests and evaluations must have been performed on a prototype generator set representative of the model specified. A summary of the generator set testing results shall be submittal for review. The manufacturer's standard series of components development tests on the generator system, engine and other major components shall be performed and available for review, but shall not be acceptable as a substitute for a prototype testing on the complete representative generator set prototype.
- D. Torsiograph Analysis and Test: The manufacturer of the generator set shall verify that the engine generator set, as configured, is free from harmful torsional stresses. The analysis shall include correlation of empirical data from tests on a representative prototype. The empirical data must include spectrum analysis of the torsional transducer output within the operating speed range of the engine generator set. Calculations based on engine and generator separately are not acceptable.
- E. Temperature Rise Test: Complete thermal evaluation of a prototype generator rotor and starter must include actual measurement of internal generator and exciter temperatures by embedded detector method, and measurement of average temperature rise by resistance method. No position measured any place in the windings may exceed the temperature rise limits of NEMA for the particular type of insulation system used. Resistance method temperature rise data shall be confirmed by a full load test on the generator set prototype to include conducted and radiated heat from the engine. A calculated temperature rise method shall also be acceptable.

- F. Short Circuit Test: A test on a prototype generator set shall have demonstrated that the generator set is designed to withstand the mechanical forces associated with a short circuit condition. With the generator set operating at rated load and speed, the generator terminals must be short circuited on all three phases for duration of 20 seconds. At the conclusion of this test, the generator set must be capable of full load operation.
- G. Endurance Run Test: A minimum of 500 continuous hours of endurance testing with a representative generator set prototype operating as defined by the manufacturer's standby rating shall have been performed. Endurance testing shall be used to verify structural soundness and durability.
- H. Maximum Power Test: With the prototype generator set at normal operating temperature and with all power consuming auxiliaries in place, the maximum power available at rated speed shall be determined with the governor set at its fuel stop. The generator set shall maintain this power for a minimum of two (2) minutes.
- I. Linear Vibration Test: A test for in-line motion of components occurring along a repeatable path shall meet the manufacturer's acceptable criteria.
- J. Cooling System Test: A cooling system test shall demonstrate the ability of the generator set cooling system to maintain normal operating temperature while operating at full rated load and power factor at the highest ambient temperature (104 °F) of the system rating. Cooling air requirements, radiator air flow and maximum allowable restriction at radiator discharge shall be verified by this test.
- K. Maximum Motor Starting KVA Test: Motor starting KVA shall be determined by test, based on a sustained RMS recovery voltage of at least 90 percent on no load voltage with the specified load KVA at near zero power factor applied to the generator set. An instantaneous motor starting calculated method shall be allowable.
- L. Transient Response, Steady State Speed Control and Voltage Regulation Test: Prototype generator set tests shall demonstrate consistent performance as follows; stable voltage and frequency at all loads from no load to full rated load, consistent frequency kp on load acceptance and rejection and restoration to steady state after sudden load changes. Transient response is a complete generator set (engine, generator, exciter, and regulator) performance criteria and cannot be established on generator data alone.
- M. Witness-Generator Set Factory Production Tests: On the equipment to be shipped, an eight-(8) hour test shall be performed at rated load and 0.8 PF. These tests shall include certified data to document the following: run at full load, maximum power, voltage regulation, transient and steady state governing, single step load pickup and safety shutdowns. Provide a factory test record of the production testing. The Contractor and/or equipment supplier at their expense shall coordinate and provide all transportation and lodging for the owner and Owner's engineering representative to witness the above stated factory test.
- N. Factory Test: The unit shall completely assembled and all preliminary adjustments made before the test is initiated.

- O. Testing Procedure:
1. Test diesel-alternator unit at 0.8 PF in the following sequence:
 2. 0.5 hour at $\frac{1}{4}$ load.
 3. 0.5 hours at $\frac{1}{2}$ load.
 4. 0.5 hours at $\frac{3}{4}$ load.
 5. 0.5 hours at full load.
- P. Above testing shall be strip chart recorded and certified. During this test, the following measurements shall be taken and recorded on a certified report format:
1. Barometric Pressure.
 2. Intake Air Pressure.
 3. RPM.
 4. Output voltage per phase.
 5. Output amperes per phase.
 6. Power Factor.
 7. KW.
 8. Transient response testing sequence:
 9. 0-25%, 25%-0.
 10. 0-50%, 50%-0.
 11. 0-75%, 75%-0.
 12. 0-100%, 100%-0.
- Q. Above testing shall be strip chart recorded. Provide necessary equipment and instruments to measure voltage dips and frequency dips. Comparison shall be made to the herein specified alternator performance characteristics prior to acceptance.
- R. Field Acceptance Tests: Generator supplier shall provide and conduct a four (4) hour load bank test at unity power factor for the generator set. Contractor shall provide portable load bank for testing generator set at 100% load. Load bank test shall test each generator at full nameplate KW ratings. Generator manufacturer's representative shall record test data, as described below. Test data shall be tabulated and typed for submission and approval by the engineer for final acceptance. No handwritten field notes will be allowed.
- S. Initial startup and field acceptance tests are to be conducted by the authorized representative of the system manufacturer who supplies the equipment. Contractor responsible for protection of testing equipment and any additional cable, etc., required if equipment cannot be located internally during testing.
- T. Test data shall be collected and recorded on the following: Time of day, coolant temperature, operating oil pressure, battery charging rate, cranking time, crank-to-rated frequency time, voltage and frequency overshoot, load assumption-to-steady state voltage and frequency stabilization time, operating voltage, frequency, current, kilowatts and power factor. All data shall be taken every fifteen (15) minutes.

1.8 QUALIFICATIONS

- A. Manufacturer: Company specializing in manufacturing the Products specified in this section with minimum ten (10) years documented experience, and with an authorized

distributor offering 24 hour parts and service availability within 50 miles of the project. Proposed engine/generator combination shall have been in production a minimum of five (5) years.

- B. Supplier: Authorized distributor of specified manufacturer with minimum five (5) years documented experience with specified products and factory-trained service technicians.

1.9 REGULATORY REQUIREMENTS

- A. Conform to requirements of NFPA 70, NFPA 110.
- B. Furnish Products listed and classified by Underwriters Laboratories as suitable for purpose specified and indicated.

1.10 PRE-INSTALLATION CONFERENCE

- A. Convene one (1) week prior to commencing work of this Section.

1.11 DELIVERY, STORAGE, AND HANDLING

- A. Deliver, store, protect and handle products in accordance with factory standards and 263213 General Conditions Specifications.

1.12 EXTRA MATERIALS

- A. Provide two (2) of each oil and air filter element, engine belts and hoses.

1.13 WARRANTY

- A. A comprehensive warranty shall be provided for all products against defects in materials and workmanship for a five-year or 1500 hour period from date of final acceptance by Owner. Warranty shall cover all costs of covered repairs, including travel expenses. Refer to 263213 General Conditions Specifications for additional requirements.

1.14 SERVICE AGREEMENT

- A. Manufacturer shall provide Owner with a one (1) year service agreement from the start-up date that includes changing all fluids and filters once a year and a minor inspection six (6) months after each change.

PART 2 - PRODUCTS

2.1 MANUFACTURERS

- A. Manufacturers: Subject to compliance with requirements, provide products by one of the following:
 1. Kinsley Power Systems, 14 Connecticut South Drive, East Cranby, CT 06026
Contact; Mr. Richard Cupillo, 860-8444-2220 (Cell 860-930-3479)

2. MTU Onsite Energy; By Atlantic Power Systems, Middletown, CT, 06457.
Contact; Mr. Michael Wynne, 860-632-0218 (Cell 860-913-4256).
3. Caterpillar; By H.O. Penn Machinery, Newington, CT, 06111.
Contact; Mr. John Stroh, 860-666-8401 (Cell 203-410-4333).
4. Cummins/Onan; By Cummins Power System, Rocky Hill, CT, 06067.
Contact; Mr. Michael Ruty, 860-721-2240 (Cell 860-558-8888).

B. Manufacturers Models: Subject to compliance with requirements, provide models as follows:

1. Kohler; Model 1250REOZDD Series.
2. MTU Onsite Energy; Model 1350DSEB Series.
3. Caterpillar; Model 3512 Series.
4. Cummins/Onan; Model 1250DQGAA Series.

2.2 DIESEL ENGINE-GENERATOR SET

A. Ratings

1. The generator set shall operate at 1800 rpm and at a voltage of: 480 Volts AC, 3-phase, 4-wire, 60 hertz.
2. The generator set shall be rated at 1250KW/1563kVA at 0.8 PF, standby rating, based on site conditions of altitude 1000 ft. and ambient temperatures up to 104°F-134°F (40°C-54°C).

B. Performance

1. Voltage regulation shall be plus or minus 0.5 percent for any constant load between no load and rated load. Random voltage variation with any steady load from no load to full load shall not exceed plus or minus 0.5 percent.
2. Frequency regulation shall be isochronous from steady state no load to steady state rated load. Random frequency variation with any steady load from no load to full load shall not exceed plus or minus 0.25%.
3. The engine-generator set shall accept a single step load of 100% nameplate kW and power factor, less applicable derating factors, with the engine-generator set at operating temperature.
4. Motor starting capability shall be a minimum of 5500KVA at 35% voltage dip. Upon application of 100% block load, generator set shall recover to rated voltage and frequency in 0-4 seconds at 0.8PF.
5. The alternator shall produce a clean AC voltage waveform, with not more than 5% total harmonic distortion at full linear load, when measured from line to neutral, and with not more than 3% in any single harmonic, and no 3rd order harmonics or their multiples. Telephone influence factor shall be less than 40.
6. The generator set shall be certified by the engine manufacturer to be suitable for use at the installed location and rating, and shall meet all applicable exhaust emission requirements at the time of commissioning.

C. Construction

1. The engine-generator set shall be mounted on a heavy-duty steel base to maintain alignment between components. The base shall incorporate a battery tray with hold-down clamps within the rails.
2. All switches, lamps, and meters in the control system shall be oil-tight and dust-tight. All active control components shall be installed within a UL/NEMA 3R enclosure. There shall be no exposed points in the control (with the door open) that operate in excess of 50 volts.

D. Connections

1. The generator set load connections shall be composed of silver or tin plated copper bus bars, drilled to accept mechanical or compression terminations of the number and type as shown on the drawings. Sufficient lug space shall be provided for use with cables of the number and size as shown on the drawings.
2. Power connections to auxiliary devices shall be made at the devices with required protection located at a wall-mounted common distribution panel (If walk-in enclosure).
3. Generator set control interfaces to other system components shall be made on a permanently labeled terminal block assembly. Labels describing connection point functions shall be provided.

2.3 ENGINE AND ENGINE EQUIPMENT

- A. The engine shall be diesel, 4 cycle, radiator and fan cooled. It shall be EPA Emissions Certified. Provide catalyst and muffler system to be internally factory mounted inside sound enclosure. The horsepower rating of the engine at its minimum tolerance level shall be sufficient to drive the alternator and all connected accessories. Two cycle engines are not acceptable.
- B. Complete engine fuel system, including all pressure regulators, strainers, and control valves. The fuel system shall be plumbed to the generator set skid for ease of site connections to the generator set. For dual fuel systems, changeover from primary to secondary fuel shall be automatic. An electronic governor system shall provide automatic isochronous frequency regulation. The governing system dynamic capabilities shall be controlled as a function of engine coolant temperature to provide fast, stable operation at varying engine operating temperature conditions. The control system shall actively control the fuel rate and excitation as appropriate to the state of the generator set. Fuel rate shall be regulated as a function of starting, accelerating to start disconnects speed, accelerating to rated speed, and operating in various isochronous or parallel states.
- C. Skid-mounted radiator and cooling system rated for full load operation in 104°F (40°C) ambient as measured at the alternator air inlet. Radiator fan shall be suitable for use in a system with 0.5 in H₂O restriction. Radiator shall be sized based on a core temperature that is 16°F-20°F higher than the rated operation temperature, or prototype tested to verify cooling performance of the engine/radiator/fan operation in a controlled environment. Radiator shall be provided with a duct adapter flange. The equipment manufacturer shall fill the cooling system with a 50/50-ethylene glycol/water mixture prior to shipping. Rotating parts shall be guarded against accidental electric starter(s) capable of three complete cranking cycles without overheating.

2.4 ENGINE ACCESSORY EQUIPMENT

- A. The engine for the generator shall include the following accessories:
1. Positive displacement, contact.
 2. Mechanical, full pressure, lubrication oil pump.
 3. Full flow lubrication oil filters with replaceable spin-on canister elements and dipstick oil level indicator.
 4. Replaceable dry element air cleaner with restriction indicator.
 5. Flexible supply and return fuel lines.
 6. Engine mounted battery charging alternator, 24 Volts DC, 70-ampere minimum, and solid-state voltage regulator.
- B. Coolant heater
1. Engine mounted thermostatically controlled, coolant heater for each engine. Heater voltage shall be as shown on the project drawings. The coolant heater shall be UL499 listed and labeled.
 2. The coolant heater shall be installed on the engine with silicone hose connections. The coolant heater installation shall be specifically designed to provide proper venting of the system. The coolant heaters shall provisions to isolate the heater for replacement of the heater element without draining the coolant from the generator set. The quick disconnect/automatic sealing couplers shall allow the heater element to be replaced without draining the engine cooling system or significant coolant loss.
 3. The coolant heater shall be provided with a 24VDC thermostat, installed at the engine thermostat housing. An AC power connection box shall be provided for a single AC power connection to the coolant heater system.
 4. The coolant heater(s) shall be sized as recommended by the engine manufacturer to warm the engine to a minimum of 104°F (40°C) in a 40°F (4°C) ambient, in compliance with NFPA110 requirements, or the temperature required for starting and load pickup requirements of this specification.
- C. Provide vibration isolators, spring/pad type, quantity as recommended by the generator set manufacturer. Isolators shall include seismic restraints rated for zone area and have bonded 1/4-inch- thick elastomeric isolator pad attached to baseplate underside.
- D. Starting and Control Batteries shall be calcium/lead antimony type, 12 volt DC, sized as recommended by the engine manufacturer, complete with battery cables and connectors. The batteries shall be capable of a minimum of three complete 15-second cranking cycles at 40 deg. F ambient temperature when fully charged.
- E. Provide exhaust silencer for each engine of size and type as recommended by the generator set manufacturer and approved by the engine manufacturer. The mufflers shall be critical grade. Provide Catalyst system as required to meet EPA standards. Muffler and Catalyst shall be internally mounted inside sound enclosure by generator manufacturer.
- F. A UL listed/CSA certified 10-12 amp voltage regulated battery charger shall be provided for each engine-generator set. Input AC voltage and DC output voltage shall be as required. Chargers shall be equipped with float, taper and equalize charge

settings. Operational monitors shall provide visual output along with individual form C contacts rated at 4 amps, 120 VAC, 30VDC for remote indication of:

1. Loss of AC power - red light
 2. Low battery voltage - red light
 3. High battery voltage - red light
 4. Power ON - green light (no relay contact)
- G. Charger shall include an Analog DC voltmeter and ammeter, 12 hour equalizing charge timer, and AC and DC fuses.

2.5 AC ALTERNATOR

- A. The AC generator shall be; synchronous, four pole, 2/3 pitch, revolving field, drip-proof construction, single pre lubricated sealed bearing, air cooled by a direct drive centrifugal blower fan, and directly connected to the engine with flexible drive disc. All insulation system components shall meet NEMA MG1 temperature limits for Class H insulation system and shall be UL1446 listed. Actual temperature rise measured by resistance method at full load shall not exceed 105°C.
- B. The generator shall be capable of delivering rated output (kVA) at rated frequency and power factor, at any voltage not more than 5 percent above or below rated voltage.
- C. A permanent magnet generator (PMG) shall be included to provide a reliable source of excitation power for optimum motor starting and short circuit performance. The PMG and controls shall be capable of sustaining and regulating current supplied to a single phase or three phase fault at approximately 300% of rated current for not more than 10 seconds.
- D. The sub-transient reactance of the alternator shall not exceed 12%-14%, based on a not to exceed 105°C rise rating.

2.6 ENGINE GENERATOR SET CONTROL

- A. Generator Set Control. The generator set shall be provided with a microprocessor-based control system that is designed to provide automatic starting, monitoring, and control functions for the generator set. The control system shall also be designed to allow local monitoring and control of the generator set, and remote monitoring and control as described in this specification.
- B. The control shall be mounted on the generator set, or may be mounted in a free-standing panel next to the generator set if adequate space and accessibility is available. The control shall be vibration isolated and prototype tested to verify the durability of all components in the system under the vibration conditions encountered.
- C. Control Switches
1. Mode Select Switch. The mode select switch shall initiate the following control modes. When in the RUN or MANUAL position the generator set shall start, and accelerate to rated speed and voltage as directed by the operator. A separate push-button to initiate starting is acceptable. In the OFF position the generator

set shall immediately stop, bypassing all time delays. In the AUTO position the generator set shall be ready to accept a signal from a remote device to start and accelerate to rated speed and voltage.

2. EMERGENCY STOP switch. Switch shall be Red "mushroom-head" push-button. Depressing the emergency stop switch shall cause the generator set to immediately shut down, and be locked out from automatic restarting.
3. RESET switch. The RESET switch shall be used to clear a fault and allow restarting the generator set after it has shut down for any fault condition.
4. PANEL LAMP switch. Depressing the panel lamp switch shall cause the entire panel to be lighted with DC control power. The panel lamps shall automatically be switched off 10 minutes after the switch is depressed, or after the switch is depressed a second time.

D. Generator Set AC Output Metering. The generator set shall be provided with a metering set including the following features and functions:

1. Digital metering set, 1% accuracy, to indicate generator RMS voltage and current, frequency, output current, output KW, KW-hours, and power factor. Generator output voltage shall be available in line-to-line and line-to-neutral voltages, and shall display all three-phase voltages (line to neutral or line to line) simultaneously.
2. The control system shall monitor the total load on the generator set, and maintain data logs of total operating hours at specific load levels ranging from 0 to 110% of rated load, in 10% increments. The control shall display hours of operation at less than 30% load and total hours of operation at more than 90% of rated load.
3. The control system shall log total number of operating hours, total KWH, and total control on hours, as well as total values since reset.

E. Generator Set Alarm and Status Display.

1. The generator set control shall include LED alarm and status indication lamps. The lamps shall be high-intensity LED type. The lamp condition shall be clearly apparent under bright room lighting conditions. Functions indicated by the lamps shall include:
2. The control shall include five configurable alarm-indicating lamps. The lamps shall be field adjustable for any status, warning, or shutdown function monitored by the generator set. They shall also be configurable for color, and control action (status, warning, or shutdown).
 - a. The control shall include green lamps to indicate that the generator set is running at rated frequency and voltage, and that a remote start signal has been received at the generator set. The running signal shall be based on actual sensed voltage and frequency on the output terminals of the generator set.
 - b. The control shall include a flashing red lamp to indicate that the control is not in automatic state, and red common shutdown lamp.
 - c. The control shall include an amber common warning indication lamp.
3. The generator set control shall indicate the existence of the warning and shutdown conditions on the control panel. All conditions indicated below for

warning shall be field-configurable for shutdown. Conditions required to be annunciated shall include:

- a. Low oil pressure (warning)
 - b. Low oil pressure (shutdown)
 - c. Oil pressure sender failure (warning)
 - d. Low coolant temperature (warning)
 - e. High coolant temperature (warning)
 - f. High coolant temperature (shutdown)
 - g. High oil temperature (warning)
 - h. Engine temperature sender failure (warning)
 - i. Low coolant level (warning)
 - j. Fail to crank (shutdown)
 - k. Fail to start/overcrank (shutdown)
 - l. Overspeed (shutdown)
 - m. Low DC voltage (warning)
 - n. High DC voltage (warning)
 - o. Weak battery (warning)
 - p. Low fuel-day tank (warning)
 - q. High AC voltage (shutdown)
 - r. Low AC voltage (shutdown)
 - s. Under frequency (shutdown)
 - t. Over current (warning)
 - u. Over current (shutdown)
 - v. Short circuit (shutdown)
 - w. Overload (warning)
 - x. Emergency stop (shutdown)
 - y. (4) configurable conditions
4. Provisions shall be made for indication of four customer-specified alarm or shutdown conditions. Labeling of the customer-specified alarm or shutdown conditions shall be of the same type and quality as the above-specified conditions. The non-automatic indicating lamp shall be red, and shall flash to indicate that the generator set is not able to automatically respond to a command to start from a remote location.

F. Engine Status Monitoring.

1. The following information shall be available from a digital status panel on the generator set control:
 - a. Engine oil pressure (psi or kPA)
 - b. Engine coolant temperature (degrees F or C)
 - c. Engine oil temperature (degrees F or C)
 - d. Engine speed (rpm)
 - e. Number of hours of operation (hours)
 - f. Number of start attempts
 - g. Battery voltage (DC volts)
2. The control system shall also incorporate a data logging and display provision to allow logging of the last 10 warning or shutdown indications on the generator set,

as well as total time of operation at various loads, as a percent of the standby rating of the generator set.

2.7 ENGINE CONTROL FUNCTIONS

- A. The control system provided shall include a cycle cranking system, which allows for user selected crank time, rest time, and # of cycles. Initial settings shall be for 3 cranking periods of 15 seconds each, with 15-second rest period between cranking periods.
- B. The control system shall include an idle mode control, which allows the engine to run in idle mode in the RUN position only. In this mode, the alternator excitation system shall be disabled. Total duration of operating time in the idle mode shall be controlled by the system, to prevent degradation of the engine capabilities due to excess operating time at idle.
- C. The control system shall include an engine governor control, which functions to provide steady state frequency regulation as noted elsewhere in this specification. The governor control shall include adjustments for gain, damping, and a ramping function to control engine speed and limit exhaust smoke while the unit is starting.
- D. The control system shall include time delay start (adjustable 0-300 seconds) and time delay stop (adjustable 0-600 seconds) functions.
- E. The control system shall include sender failure monitoring logic for speed sensing, oil pressure, and engine temperature which is capable of discriminating between failed sender or wiring components, and actual failure conditions.

2.8 ALTERNATOR CONTROL FUNCTIONS

- A. The generator set shall include a full wave rectified automatic digital voltage regulation system that is matched and prototype tested by the engine manufacturer with the governing system provided. It shall be immune from misoperation due to load-induced voltage waveform distortion and provide a pulse width modulated output to the alternator exciter. The voltage regulation system shall be equipped with three-phase line to neutral RMS sensing and shall control buildup of AC generator voltage to provide a linear rise and limit overshoot. The system shall include a torque-matching characteristic, which shall reduce output voltage in proportion to frequency below an adjustable frequency threshold. Torque matching characteristic shall be adjustable for roll-off frequency and rate, and be capable of being curve-matched to the engine torque curve with adjustments in the field. The voltage regulator shall include adjustments for gain, damping, and frequency roll-off. Adjustments shall be broad range, and made via digital raise-lower switches, with an alphanumeric LED readout to indicate setting level. Rotary potentiometers for system adjustments are not acceptable.
- B. Controls shall be provided to monitor the output current of the generator set and initiate an alarm (over current warning) when load current exceeds 110% of the rated current of the generator set on any phase for more than 60 seconds. The controls shall shut down and lock out the generator set when output current level approaches the thermal

damage point of the alternator (over current shutdown). The protective functions provided shall be in compliance to the requirements of NFPA70 article 445.

- C. Controls shall be provided to individually monitor all three phases of the output current for short circuit conditions. The control/protection system shall monitor the current level and voltage. The controls shall shut down and lock out the generator set when output current level approaches the thermal damage point of the alternator (short circuit shutdown). The protective functions provided shall be in compliance to the requirements of NFPA70 Article 445.
- D. An AC over/under voltage monitoring system that responds only to true RMS voltage conditions shall be provided. The system shall initiate shutdown of the generator set when alternator output voltage exceeds 110% of the operator-set voltage level for more than 10 seconds, or with no intentional delay when voltage exceeds 130%. Under voltage shutdown shall occur when the output voltage of the alternator is less than 85% for more than 10 seconds.

2.9 OTHER CONTROL FUNCTIONS

- A. A battery monitoring system shall be provided which initiates alarms when the DC control and starting voltage is less than 25VDC or more than 32 VDC. During engine cranking (starter engaged), the low voltage limit shall be disabled, and DC voltage shall be monitored as load is applied to the battery, to detect impending battery failure or deteriorated battery condition.

2.10 FUEL STORAGE TANK

- A. Comply with NFPA 30.
- B. Sub-Base Tank: Comply with UL 142, fuel tank assembly, with the following features:
 - 1. Containment: Integral rupture basin with a capacity of 110% of nominal capacity of tank.
 - 2. Leak Detector: Locate in rupture basin and connect to provide audible and visual alarm in the event of tank leak.
 - 3. Tank Capacity: 72 hours at 100% load.
 - 4. Pump Capacity: Exceeds maximum flow of fuel drawn by engine-mounted fuel supply pump at 110 percent of rated capacity, including fuel returned from engine.
 - 5. Low-Level Alarm Sensor: Liquid-level device operates alarm contacts at 25 percent of normal fuel level.
 - 6. High-Level Alarm Sensor: Liquid-level device operates alarm and redundant fuel shutoff contacts at midpoint between overflow level and 100 percent of normal fuel level.

2.11 GENERATOR ACCESSORIES

- A. The generator set shall be provided with a set mounted two (2) molded case 65,000AIC main line circuit breakers. The circuit breakers shall be 100% rated solid state electronic type with long, short, instantaneous (LSI) trip features. Unit shall protect the alternator under all overcurrent conditions. The supplier shall submit time

overcurrent characteristic curves and thermal damage curve for the alternator, demonstrating the effectiveness of the protection provided. The supplier shall also take responsibility to provide the proper microprocessor trip unit and LSI settings in the mainline breaker that will selectively coordinate with all downstream emergency distribution overcurrent protective devices directly connected.

- B. Provide one serial Modbus RS-485 Network Card. Provide start-up/programming and mapping register for IT support to enter mapping points via Modbus.
- C. Remote Alarm Annunciator: Comply with NFPA 99. An LED labeled with proper alarm conditions shall identify each alarm event and a common audible signal shall sound for each alarm condition. Silencing switch in face of panel shall silence signal without altering visual indication. Connect so that after an alarm is silenced, clearing of initiating condition will reactivate alarm until silencing switch is reset.

2.12 SKIN-TIGHT SOUND ENCLOSURE

- A. Sound Attenuation: Enclosure shall not exceed 75dBA @ 23ft. Entire assembly shall be able to reduce generator set noise in free field to listed attenuation at distance in any direction.
- B. Steel Skin: Enclosure to be covered with finished marine grade steel panels. Include cost for custom color as selected by Owner. Covering to be separated from structural steel with 1/8" closed cell rubber foam insulation. All fasteners to be made of non-corrosive materials. All panel fasteners will not be visible on the exterior. Roof panel joints to have continuous covers, sealed and secured to steel frame with corrosion resistant fasteners.
- C. Accessories: Muffler brackets to be solid aluminum structural angle, welded as one piece for internal installation from a super critical sound absorber muffler. Muffler straps provided to be custom fit for the muffler. Insulation for interior muffler/flex and exhaust pipe provided and installed. Aluminum rain caps and collars made to prevent rain intrusion at roof penetration. Engine oil and water drains to be extended to exterior of enclosure.
- D. Base Description: Built from 7 gauge steel plate, 12" channel, and 7 gauge steel floor with electrical stub up areas. Provide 4 point lift rings, prime and painted with black enamel.
- E. Electrical Accessories:
 - 1. Junction box for ancillary components requiring field circuitry.
 - 2. Duplex receptacle(s).
 - 3. Remote weatherproof emergency stop switch.

PART 3 - EXECUTION

3.1 EXAMINATION

- A. Examine areas, equipment bases, and conditions, with Installer present, for compliance with requirements for installation and other conditions affecting packaged engine-generator performance.
- B. Examine roughing-in of piping systems and electrical connections. Verify actual locations of connections before packaged engine-generator installation.
- C. Proceed with installation only after unsatisfactory conditions have been corrected.

3.2 INSTALLATION

- A. Coordinate with Electric Contractor the packaged engine-generator manufacturers' written installation and alignment instructions and with NFPA 110.
- B. Coordinate with Electric Contractor for installation of packaged engine generator to provide access, without removing connections or accessories, for periodic maintenance.
- C. Coordinate with Electric Contractor for installation of packaged engine generator with restrained spring isolators having a minimum deflection of 1 inch on 4-inch- high concrete base. Contractor to secure set to anchor bolts installed in concrete bases.
- D. Electrical Wiring: Coordinate with Electric Contractor electrical devices furnished by equipment manufacturers but not specified to be factory mounted.

3.3 FIELD QUALITY CONTROL

- A. Perform tests and inspections and prepare test reports.
 1. Manufacturer's Field Service: Provide a factory-authorized service representative to inspect components, assemblies, and equipment installations, including connections, and to assist Electric Contractor in testing.
- B. Tests and Inspections:
 1. Tests shall be as recommended by manufacturer's factory engineer and each electrical test and visual and mechanical inspection (except those indicated to be optional) for "AC Generators and for Emergency Systems" specified in NETA Acceptance Testing Specification. Certify compliance with test parameters.
 2. Building Load Test: Electric Contractor to perform after set is installed.
 3. Battery Tests: Electric Contractor to equalize charging of battery cells according to manufacturer's written instructions. Record individual cell voltages.
 - a. Measure charging voltage and voltages between available battery terminals for full-charging and float-charging conditions. Check electrolyte level and specific gravity under both conditions.
 - b. Test for contact integrity of all connectors. Perform an integrity load test and a capacity load test for the battery.
 - c. Verify acceptance of charge for each element of the battery after discharge.
 - d. Verify that measurements are within manufacturer's specifications.

4. Battery-Charger Tests: Electric Contractor to verify specified rates of charge for both equalizing and float-charging conditions.
 5. System Integrity Tests: Electric Contractor to methodically verify proper installation, connection, and integrity of each element of engine-generator system before and during system operation. Check for air, exhaust, and fluid leaks.
 6. Exhaust Emissions Test: Electric Contractor to comply with applicable State and Local Government test criteria.
- C. Coordinate tests with tests for transfer switches and run them concurrently.
- D. Leak Test: After installation, Electric Contractor to charge system and test for leaks. Repair leaks and retest until no leaks exist.
- E. Operational Test: After electrical circuitry has been energized, Electric Contractor to start units to confirm proper motor rotation and unit operation.
- F. Test and adjust controls and safeties. Replace damaged and malfunctioning controls and equipment.
- G. Remove and replace malfunctioning units and retest as specified above.
- H. Retest: Correct deficiencies identified by tests and observations and retest until specified requirements are met.
- I. Report results of tests and inspections in writing. Record adjustable relay settings and measured insulation resistances, time delays, and other values and observations. Attach a label or tag to each tested component indicating satisfactory completion of tests.
- J. Infrared Scanning: After Substantial Completion, but not more than 60 days after Final Acceptance, Electric Contractor to perform an infrared scan of each power wiring termination and each bus connection. All access panels shall be removed so terminations and connections are accessible to portable scanner.
1. Follow-up Infrared Scanning: Perform an additional follow-up infrared scan 11 months after date of Substantial Completion.
 2. Instrument: Use an infrared scanning device designed to measure temperature or to detect significant deviations from normal values. Provide calibration record for device.
 3. Record of Infrared Scanning: Prepare a certified report that identifies terminations and connections checked and that describes scanning results. Include notation of deficiencies detected, remedial action taken and observations after remedial action.

3.4 ACCEPTANCE

- A. Equipment shall be initially started and operated by representatives of the manufacturer.
- B. All equipment shall be physically inspected for damage. Scratches and other installation damage shall be repaired prior to final system testing. Equipment shall be

thoroughly cleaned to remove all dirt and construction debris prior to final testing of the system.

3.5 TRAINING

- A. The equipment supplier shall provide training for the facility operating personnel covering operation and maintenance of the equipment provided. The training program shall be not less than two (2) four (4) hours sessions in duration and the class size shall be limited to five (5) persons. Training date shall be coordinated with the facility owner.

3.6 DEMONSTRATION

- A. The equipment supplier shall train Owner's maintenance personnel to adjust, operate, and maintain packaged engine generators.
- B. Electric Contractor shall provide fuel for testing and shall fill tank complete after all testing is done and before turning over to Owner.
- C. Describe loads connected to standby system and restrictions for future load additions.
- D. Simulate power outage by interrupting normal source, and demonstrate that system operates to provide standby power.

END OF SECTION 263213(DEG)

SECTION 263600 – AUTOMATIC TRANSFER SWITCHES

PART 1 - GENERAL

1.1 RELATED DOCUMENTS

- A. Drawings and general provisions of the Contract, including General and Supplementary Conditions and Division 01 Specification Sections, apply to this Section.

1.2 SUMMARY

- A. This Section includes transfer switches rated 600 V and less, including the following:
 - 1. Automatic transfer switches.
 - 2. Bypass/isolation switches.
 - 3. Remote annunciation systems.

1.3 SUBMITTALS

- A. Product Data: For each type of product indicated. Include rated capacities, weights, operating characteristics, furnished specialties, and accessories.
- B. Shop Drawings: Dimensioned plans, elevations, sections, and details showing minimum clearances, conductor entry provisions, gutter space, installed features and devices, and material lists for each switch specified.
 - 1. Single-Line Diagram: Show connections between transfer switch, bypass/isolation switch, power sources, and load; and show interlocking provisions for each combined transfer switch and bypass/isolation switch.
- C. Manufacturer Seismic Qualification Certification: Submit certification that transfer switches accessories, and components will withstand seismic forces as established by the applicable industry standards. Include the following:
 - 1. Basis for Certification: Indicate whether withstand certification is based on actual test of assembled components or on calculation.
 - a. The term "withstand" means "the unit will remain in place without separation of any parts from the device when subjected to the seismic forces specified and the unit will be fully operational after the seismic event."
 - 2. Dimensioned Outline Drawings of Equipment Unit: Identify center of gravity and locate and describe mounting and anchorage provisions.
 - 3. Detailed description of equipment anchorage devices on which the certification is based and their installation requirements.

- D. Qualification Data: For manufacturer and testing agency.
- E. Field quality-control test reports.
- F. Operation and Maintenance Data: For each type of product to include in emergency operation, and maintenance manuals. In addition to items specified in Division 01 Section "Operation and Maintenance Data," include the following:
 - 1. Features and operating sequences, both automatic and manual.
 - 2. List of all factory settings of relays; provide relay-setting and calibration instructions, including software, where applicable.

1.4 QUALITY ASSURANCE

- A. Manufacturer Qualifications: Maintain a service center capable of providing training, parts, and emergency maintenance repairs within a response period of less than (four) 4, hours from time of notification.
- B. Testing Agency Qualifications: An independent agency, with the experience and capability to conduct the testing indicated, that is a member company of the InterNational Electrical Testing Association or is a nationally recognized testing laboratory (NRTL) as defined by OSHA in 29 CFR 1910.7, and that is acceptable to authorities having jurisdiction.
 - 1. Testing Agency's Field Supervisor: Person currently certified by the InterNational Electrical Testing Association or the National Institute for Certification in Engineering Technologies to supervise on-site testing specified in Part 3.
- C. Source Limitations: Obtain automatic transfer switches, bypass/isolation switches and remote annunciators through one source from a single manufacturer.
- D. Electrical Components, Devices, and Accessories: Listed and labeled as defined in NFPA 70, Article 100, by a testing agency acceptable to authorities having jurisdiction, and marked for intended use.
- E. Comply with NEMA ICS 1.
- F. Comply with NFPA 70.
- G. Comply with NFPA 110.
- H. Comply with UL 1008 unless requirements of these Specifications are stricter.

1.5 PROJECT CONDITIONS

- A. Interruption of Existing Electrical Service: Do not interrupt electrical service to facilities occupied by Owner or others unless permitted under the following conditions and then only after arranging to provide temporary electrical service:

1. Notify Architect and Owner no fewer than (five) 5 days in advance of proposed interruption of electrical service.
2. Do not proceed with interruption of electrical service without Architect's and Owner's written permission.

1.6 COORDINATION

- A. Coordinate size and location of concrete bases. Cast anchor-bolt inserts into bases. Concrete, reinforcement, and formwork requirements are specified in Division 03.

PART 2 - PRODUCTS

2.1 MANUFACTURERS

- A. Available Manufacturers: Subject to compliance with requirements, manufacturers offering products that may be incorporated into the Work include, but are not limited to, the following:
- B. Manufacturers: Subject to compliance with requirements, provide products by one of the following:
 1. Contactor Transfer Switches:
 - a. Caterpillar; Engine Div.
 - b. Emerson; ASCO Power Technologies, LP.
 - c. Kohler Power Systems; Generator Division.
 - d. Onan/Cummins Power Generation; Industrial Business Group.
 - e. Atlantic Detroit Diesel.

2.2 GENERAL TRANSFER-SWITCH PRODUCT REQUIREMENTS

- A. Indicated Current Ratings: Apply as defined in UL 1008 for continuous loading and total system transfer, including tungsten filament lamp loads not exceeding 30 percent of switch ampere rating, unless otherwise indicated.
- B. Tested Fault-Current Closing and Withstand Ratings: Adequate for duty imposed by protective devices at installation locations in Project under the fault conditions indicated, based on testing according to UL 1008.
- C. Solid-State Controls: Repetitive accuracy of all settings shall be plus or minus 2 percent or better over an operating temperature range of minus 20 to plus 70 deg C.
- D. Resistance to Damage by Voltage Transients: Components shall meet or exceed voltage-surge withstand capability requirements when tested according to IEEE C62.41. Components shall meet or exceed voltage-impulse withstand test of NEMA ICS 1.

- E. Electrical Operation: Accomplish by a non-fused, momentarily energized solenoid or electric-motor-operated mechanism, mechanically and electrically interlocked in both directions.
- F. Switch Characteristics: Designed for continuous-duty repetitive transfer of full-rated current between active power sources.
 - 1. Limitation: Switches using molded-case switches or circuit breakers or insulated-case circuit-breaker components are not acceptable.
 - 2. Switch Action: Double throw; mechanically held in both directions.
 - 3. Contacts: Silver composition or silver alloy for load-current switching. Conventional automatic transfer-switch units, rated 225 A and higher, shall have separate arcing contacts.
- G. Neutral Terminal: Solid and fully rated, unless otherwise indicated.
- H. Battery Charger: For generator starting batteries.
 - 1. Float type rated 10A.
 - 2. Ammeter to display charging current.
 - 3. Fused ac inputs and dc outputs.
- I. Annunciation, Control, and Programming Interface Components: Devices at transfer switches for communicating with remote programming devices, annunciators, or annunciator and control panels shall have communication capability matched with remote device.
- J. Factory Wiring: Train and bundle factory wiring and label, consistent with Shop Drawings, either by color-code or by numbered or lettered wire and cable tape markers at terminations. Color-coding and wire and cable tape markers are provided in accordance with applicable Sections of the National Electrical Code and as specified in the applicable industry standards.
 - 1. Designated Terminals: Pressure type, suitable for types and sizes of field wiring indicated.
 - 2. Power-Terminal Arrangement and Field-Wiring Space: Suitable for top, side, or bottom entrance of feeder conductors as indicated.
 - 3. Control Wiring: Equipped with lugs suitable for connection to terminal strips.
- K. Enclosures: General-purpose NEMA 250, Type 1, complying with NEMA ICS 6 and UL 508, unless otherwise indicated.

2.3 OPEN TRANSITION TYPE AUTOMATIC TRANSFER SWITCHES

- A. Comply with Level 1 equipment according to NFPA 110.
- B. Switching Arrangement: Double-throw type, incapable of pauses or intermediate position stops during normal functioning, unless otherwise indicated.

- C. Manual Switch Operation: Under load, with door closed and with either or both sources energized. Transfer time is same as for electrical operation. Control circuit automatically disconnects from electrical operator during manual operation.
- D. Digital Communication Interface: Matched to capability of remote annunciator or annunciator and control panel.
 - 1. Failure of power source serving load initiates automatic break-before-make transfer.
- E. In-Phase Monitor: Factory-wired, internal relay controls transfer so it occurs only when the two sources are synchronized in phase. Relay compares phase relationship and frequency difference between normal and emergency sources and initiates transfer when both sources are within 15 electrical degrees, and only if transfer can be completed within 60 electrical degrees. Transfer is initiated only if both sources are within 2 Hz of nominal frequency and 70 percent or more of nominal voltage.
- F. Motor Disconnect and Timing Relay: Controls designate starters so they disconnect motors before transfer and reconnect them selectively at an adjustable time interval after transfer. Control connection to motor starters is through wiring external to automatic transfer switch. Time delay for reconnecting individual motor loads is adjustable between 1 and 60 seconds, and settings are as indicated. Relay contacts handling motor-control circuit inrush and seal currents are rated for actual currents to be encountered.
- G. Programmed Neutral Switch Position: Switch operator has a programmed neutral position arranged to provide a midpoint between the two working switch positions, with an intentional, time-controlled pause at midpoint during transfer. Pause is adjustable from 0.5 to 30 seconds minimum and factory set for 0.5 second, unless otherwise indicated. Time delay occurs for both transfer directions. Pause is disabled unless both sources are live.
- H. Automatic Transfer-Switch Features:
 - 1. Undervoltage Sensing for Each Phase of Normal Source: Sense low phase-to-ground voltage on each phase. Pickup voltage shall be adjustable from 85 to 100 percent of nominal, and dropout voltage is adjustable from 75 to 98 percent of pickup value. Factory set for pickup at 90 percent and dropout at 85 percent.
 - 2. Adjustable Time Delay: For override of normal-source voltage sensing to delay transfer and engine start signals. Adjustable from zero to six seconds, and factory set for one second.
 - 3. Voltage/Frequency Lockout Relay: Prevent premature transfer to generator. Pickup voltage shall be adjustable from 85 to 100 percent of nominal. Factory set for pickup at 90 percent. Pickup frequency shall be adjustable from 90 to 100 percent of nominal. Factory set for pickup at 95 percent.
 - 4. Time Delay for Retransfer to Normal Source: Adjustable from 0 to 30 minutes, and factory set for 10 minutes to automatically defeat delay on loss of voltage or sustained under voltage of emergency source, provided normal supply has been restored.
 - 5. Test Switch: Simulate normal-source failure.
 - 6. Switch-Position Pilot Lights: Indicate source to which load is connected.

7. Source-Available Indicating Lights: Supervise sources via transfer-switch normal- and emergency-source sensing circuits.
 - a. Normal Power Supervision: Green light with nameplate engraved "Normal Source Available."
 - b. Emergency Power Supervision: Red light with nameplate engraved "Emergency Source Available."
8. Unassigned Auxiliary Contacts: Two normally open, single-pole, double-throw contacts for each switch position, rated 10 A at 240-V ac.
9. Transfer Override Switch: Overrides automatic retransfer control so automatic transfer switch will remain connected to emergency power source regardless of condition of normal source. Pilot light indicates override status.
10. Engine Starting Contacts: One isolated and normally closed, and one isolated and normally open; rated 10 A at 32-V dc minimum.
11. Engine Shutdown Contacts: Time delay adjustable from zero to five minutes, and factory set for five minutes. Contacts shall initiate shutdown at remote engine-generator controls after retransfer of load to normal source.
12. Engine-Generator Exerciser: Solid-state, programmable-time switch starts engine generator and transfers load to it from normal source for a preset time, then retransfers and shuts down engine after a preset cool-down period. Initiates exercise cycle at preset intervals adjustable from 7 to 30 days. Running periods are adjustable from 10 to 30 minutes. Factory settings are for 7-day exercise cycle, 20-minute running period, and 5-minute cool-down period. Exerciser features include the following:
 - a. Exerciser Transfer Selector Switch: Permits selection of exercise with and without load transfer.
 - b. Push-button programming control with digital display of settings.
 - c. Integral battery operation of time switch when normal control power is not available.

2.4 BYPASS/ISOLATION SWITCHES

- A. Comply with requirements for Level 1 equipment according to NFPA 110.
- B. Description: Manual type, arranged to select and connect either source of power directly to load, isolating transfer switch from load and from both power sources. Include the following features for each combined automatic transfer switch and bypass/isolation switch:
 1. Means to lock bypass/isolation switch in the position that isolates transfer switch with an arrangement that permits complete electrical testing of transfer switch while isolated. While isolated, interlocks prevent transfer-switch operation, except for testing or maintenance.
 2. Draw-out Arrangement for Transfer Switch: Provide physical separation from live parts and accessibility for testing and maintenance operations.
 3. Bypass/Isolation Switch Current, Voltage, Closing, and Short-Circuit Withstand Ratings: Equal to or greater than those of associated automatic transfer switch, and with same phase arrangement and number of poles.

4. Contact temperatures of bypass/isolation switches shall not exceed those of automatic transfer-switch contacts when they are carrying rated load.
 5. Operability: Constructed so load bypass and transfer-switch isolation can be performed by 1 person in no more than 2 operations in 15 seconds or less.
 6. Legend: Manufacturer's standard legend for control labels and instruction signs shall describe operating instructions.
 7. Maintainability: Fabricate to allow convenient removal of major components from front without removing other parts or main power conductors.
- C. Interconnection of Bypass/Isolation Switches with Automatic Transfer Switches: Factory-installed copper bus bars; plated at connection points and braced for the indicated available short-circuit current.

2.5 REMOTE ANNUNCIATOR SYSTEM

- A. Functional Description: Remote annunciator panel shall annunciate conditions for indicated transfer switches. Annunciation shall include the following:
1. Sources available, as defined by actual pickup and dropout settings of transfer-switch controls.
 2. Switch position.
 3. Switch in test mode.
 4. Failure of communication link.
- B. Annunciator Panel: LED-lamp type with audible signal and silencing switch.
1. Indicating Lights: Grouped for each transfer switch monitored.
 2. Label each group, indicating transfer switch it monitors, location of switch, and identity of load it serves.
 3. Mounting: Flush, modular, steel cabinet, unless otherwise indicated.
 4. Lamp Test: Push-to-test or lamp-test switch on front panel.

2.6 SOURCE QUALITY CONTROL

- A. Factory test and inspect components, assembled switches, and associated equipment. Ensure proper operation. Check transfer time and voltage, frequency, and time-delay settings for compliance with specified requirements. Perform dielectric strength test complying with NEMA ICS 1.

PART 3 - EXECUTION

3.1 INSTALLATION

- A. Design each fastener and support to carry load indicated by seismic requirements and according to seismic-restraint details. See Division 26 Section "Vibration and Seismic Controls for Electrical Systems."

- B. Floor-Mounting Switch: Anchor to floor by bolting.
 - 1. Concrete Bases: 4 inches (100 mm) high, reinforced, with chamfered edges. Extend base no more than 4 inches (100 mm) in all directions beyond the maximum dimensions of switch, unless otherwise indicated or unless required for seismic support. Construct concrete bases according to Division 26 Section "Hangers and Supports for Electrical Systems."
- C. Annunciator and Control Panel Mounting: Flush in wall, unless otherwise indicated.
- D. Identify components according to Division 26 Section "Identification for Electrical Systems."
- E. Set field-adjustable intervals and delays, relays, and engine exerciser clock.

3.2 CONNECTIONS

- A. Wiring to Remote Components: Match type and number of cables and conductors to control and communication requirements of transfer switches as recommended by manufacturer. Increase raceway sizes at no additional cost to Owner if necessary to accommodate required wiring.
- B. Ground equipment in accordance with the applicable Sections of the National Electrical Code (NEC).
- C. Connect wiring in accordance with the applicable Sections of NEC.

3.3 FIELD QUALITY CONTROL

- A. Testing Agency: Owner will engage a qualified independent testing and inspecting agency to perform tests and inspections and prepare test reports.
- B. Manufacturer's Field Service: Engage a factory-authorized service representative to inspect, test, and adjust components, assemblies, and equipment installations, including connections. Report results in writing.
- C. Perform tests and inspections and prepare test reports.
 - 1. Manufacturer's Field Service: Engage a factory-authorized service representative to inspect components, assemblies, and equipment installation, including connections, and to assist in testing.
 - 2. After installing equipment and after electrical circuitry has been energized, test for compliance with requirements.
 - 3. Perform each visual and mechanical inspection and electrical test stated in NETA Acceptance Testing Specification. Certify compliance with test parameters.
 - 4. Measure insulation resistance phase-to-phase and phase-to-ground with insulation-resistance tester. Include external annunciation and control circuits. Use test voltages and procedure recommended by manufacturer. Comply with manufacturer's specified minimum resistance.

- a. Check for electrical continuity of circuits and for short circuits.
 - b. Inspect for physical damage, proper installation and connection, and integrity of barriers, covers, and safety features.
 - c. Verify that manual transfer warnings are properly placed.
 - d. Perform manual transfer operation.
5. After energizing circuits, demonstrate interlocking sequence and operational function for each switch at least three times.
- a. Simulate power failures of normal source to automatic transfer switches and of emergency source with normal source available.
 - b. Simulate loss of phase-to-ground voltage for each phase of normal source.
 - c. Verify time-delay settings.
 - d. Verify pickup and dropout voltages by data readout or inspection of control settings.
 - e. Test bypass/isolation unit functional modes and related automatic transfer-switch operations.
 - f. Verify proper sequence and correct timing of automatic engine starting, transfer time delay, retransfer time delay on restoration of normal power, and engine cool-down and shutdown.
6. Ground-Fault Tests: Coordinate with testing of ground-fault protective devices for power delivery from both sources.
- a. Verify grounding connections and locations and ratings of sensors.
- D. Testing Agency's Tests and Inspections:
1. After installing equipment and after electrical circuitry has been energized, test for compliance with requirements.
 2. Perform each visual and mechanical inspection and electrical test stated in NETA Acceptance Testing Specification. Certify compliance with test parameters.
 3. Measure insulation resistance phase-to-phase and phase-to-ground with insulation-resistance tester. Include external annunciation and control circuits. Use test voltages and procedure recommended by manufacturer. Comply with manufacturer's specified minimum resistance.
 - a. Check for electrical continuity of circuits and for short circuits.
 - b. Inspect for physical damage, proper installation and connection, and integrity of barriers, covers, and safety features.
 - c. Verify that manual transfer warnings are properly placed.
 - d. Perform manual transfer operation.
 4. After energizing circuits, demonstrate interlocking sequence and operational function for each switch at least three times.
 - a. Simulate power failures of normal source to automatic transfer switches and of emergency source with normal source available.
 - b. Simulate loss of phase-to-ground voltage for each phase of normal source.
 - c. Verify time-delay settings.

- d. Verify pickup and dropout voltages by data readout or inspection of control settings.
 - e. Test bypass/isolation unit functional modes and related automatic transfer-switch operations.
 - f. Verify proper sequence and correct timing of automatic engine starting, transfer time delay, retransfer time delay on restoration of normal power, and engine cool-down and shutdown.
5. Ground-Fault Tests: Coordinate with testing of ground-fault protective devices for power delivery from both sources.
- a. Verify grounding connections and locations and ratings of sensors.
- E. Coordinate tests with tests of generator and run them concurrently.
- F. Report results of tests and inspections in writing. Record adjustable relay settings and measured insulation and contact resistances and time delays. Attach a label or tag to each tested component indicating satisfactory completion of tests.
- G. Remove and replace malfunctioning units and retest as specified above.
- H. Infrared Scanning: After Substantial Completion, but not more than 60 days after Final Acceptance, perform an infrared scan of each switch. Remove all access panels so joints and connections are accessible to portable scanner.
1. Follow-up Infrared Scanning: Perform an additional follow-up infrared scan of each switch 11 months after date of Substantial Completion.
 2. Instrument: Use an infrared scanning device designed to measure temperature or to detect significant deviations from normal values. Provide calibration record for device.
 3. Record of Infrared Scanning: Prepare a certified report that identifies switches checked and that describes scanning results. Include notation of deficiencies detected, remedial action taken and observations after remedial action.

3.4 DEMONSTRATION

- A. Engage a factory-authorized service representative to train Owner's maintenance personnel to adjust, operate, and maintain transfer switches and related equipment as specified below. Refer to Division 01 Section "Demonstration and Training."
- B. Coordinate this training with that for generator equipment.

END OF SECTION 263600

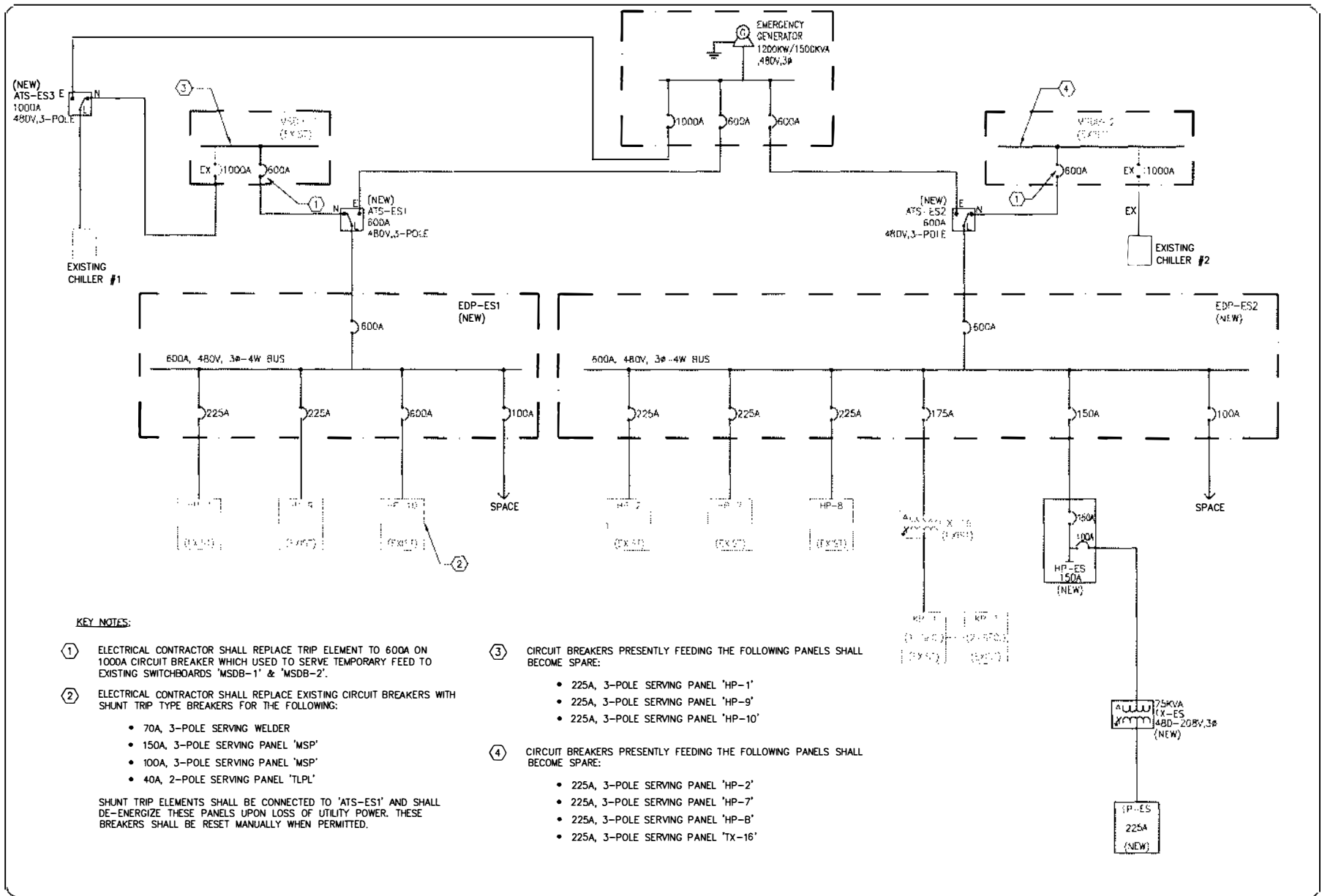

AKF

Project TRUMBULL H.S. SHELTER GENERATOR
 Title ELECTRICAL ONE LINE DIAGRAM - ADD ALTERNATE
 Project No. S130005 Date 12/05/2013 Chkd By HAP

Sketch No. E-2
 Scale N.T.S.

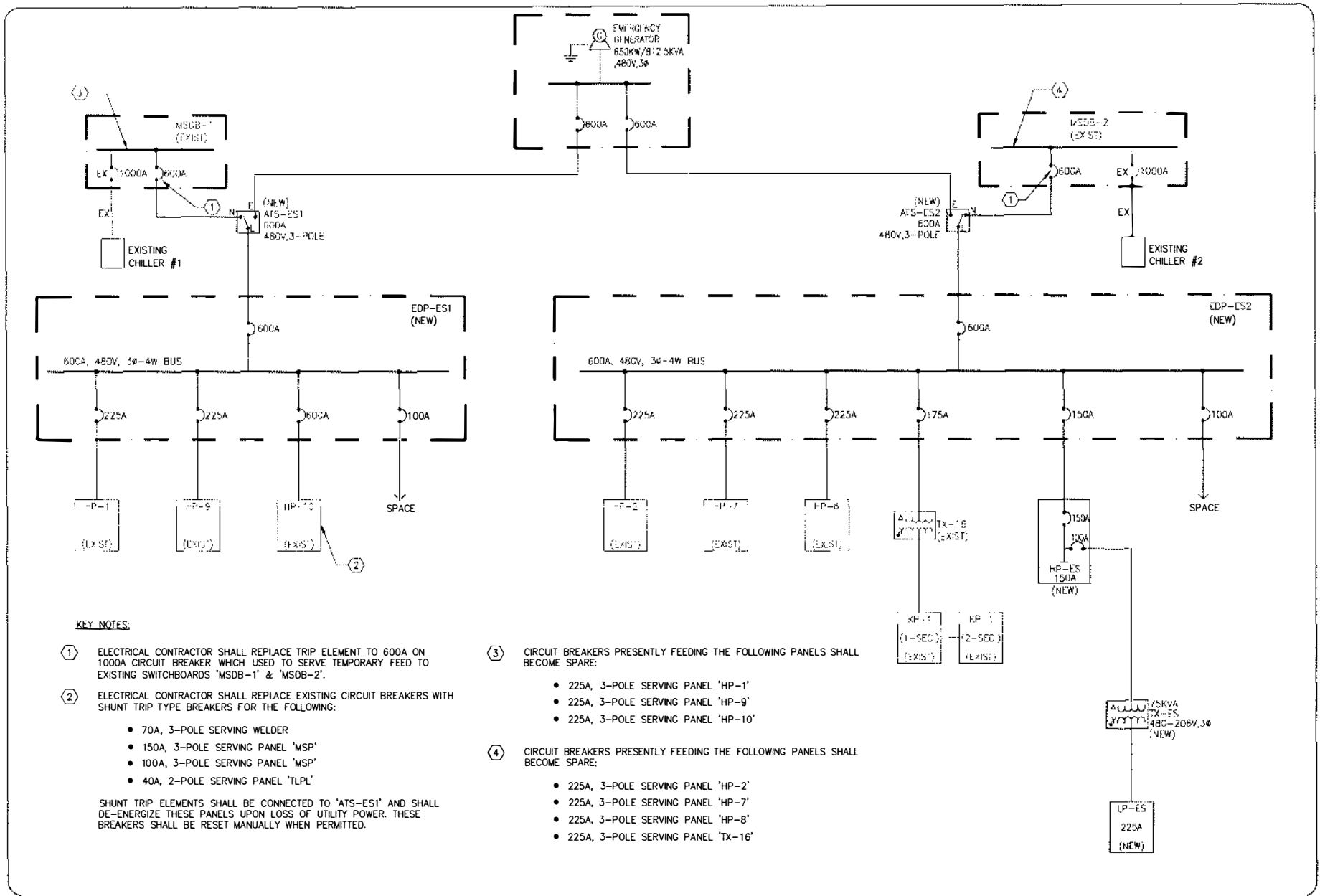

KEY NOTES:

- ① ELECTRICAL CONTRACTOR SHALL REPLACE TRIP ELEMENT TO 600A ON 1000A CIRCUIT BREAKER WHICH USED TO SERVE TEMPORARY FEED TO EXISTING SWITCHBOARDS 'MSDB-1' & 'MSDB-2'.
- ② ELECTRICAL CONTRACTOR SHALL REPLACE EXISTING CIRCUIT BREAKERS WITH SHUNT TRIP TYPE BREAKERS FOR THE FOLLOWING:
 - 70A, 3-POLE SERVING WELDER
 - 150A, 3-POLE SERVING PANEL 'MSP'
 - 100A, 3-POLE SERVING PANEL 'MSP'
 - 40A, 2-POLE SERVING PANEL 'TLPL'

SHUNT TRIP ELEMENTS SHALL BE CONNECTED TO 'ATS-ES1' AND SHALL DE-ENERGIZE THESE PANELS UPON LOSS OF UTILITY POWER. THESE BREAKERS SHALL BE RESET MANUALLY WHEN PERMITTED.

- ③ CIRCUIT BREAKERS PRESENTLY FEEDING THE FOLLOWING PANELS SHALL BECOME SPARE:
 - 225A, 3-POLE SERVING PANEL 'HP-1'
 - 225A, 3-POLE SERVING PANEL 'HP-9'
 - 225A, 3-POLE SERVING PANEL 'HP-10'
- ④ CIRCUIT BREAKERS PRESENTLY FEEDING THE FOLLOWING PANELS SHALL BECOME SPARE:
 - 225A, 3-POLE SERVING PANEL 'HP-2'
 - 225A, 3-POLE SERVING PANEL 'HP-7'
 - 225A, 3-POLE SERVING PANEL 'HP-8'
 - 225A, 3-POLE SERVING PANEL 'TX-16'



Project TRUMBULL H.S. SHELTER GENERATOR
 Title ELECTRICAL ONE LINE DIAGRAM - BASE BID
 Project No. S130005 Date 12/05/2013 Chkd By HAP

Sketch No. F-1
 Scale NTS

